

SC-100

NAKAMURA-TOME
PRECISION INDUSTRY CO.,LTD.

Simple but beyond
expectations

Innovation
Technology

~ Creation of new values ~

SC-100

A high-performance compact 6-Inch Turning Center with one turret, to complete the SC-Series product line.

Our benchmarks are "High Rigidity", "High Precision" and "User-Friendliness".

Through its well-designed mechanical structure and flexible packages, a wide range of parts can be machined, fulfilling various market needs.

- Milling and Y-axis are standard
- Y-axis travel is 80mm (±40mm)
- 7.1/2.2kW Milling motor / Spindle Max. speed 6,000min⁻¹
- 7.5/5.5kW Sub-spindle (option)
- Parts Catcher A with integrated parts conveyor for sub-spindle specifications.
- High rigidity design
- Z-axis travel 400mm
- Floor space 2,268mm×1,700mm (Standard Specifications)
- 100% recovery of lubrication oil (for Standard Specs. ; theoretical value)
- Environment-Friendly Inverter-type hydraulic unit

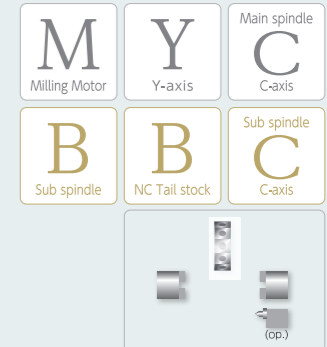

※ 1 SC-100(Mata-Bei Specifications)



※ 2 SC-100(Standard Specifications)

Compact machine with high machining capabilities



SC-100 is a first-class machine, featuring high-performance machining in a small foot-print, which is one of the merits of Nakamura-Tome machines.

In addition to Milling and Y-axis, which are standard equipment, several packages are available to respond to the needs of various industries.

The robust bed casting design, which is the base of the machine, contributes to improved stiffness.

By introducing "NT Thermo Navigator", thermal growth is drastically reduced, ensuring thermal-stability and high-accuracy machining.

Nakamura-Tome design does not focus only on machining capabilities, but also on high rigidity and high accuracy.

NT Thermo Navigator

Amount of Thermal displacement amount **4.5 μ m**

※Actual Values shown here are obtained when ambient temperature conditions are met.

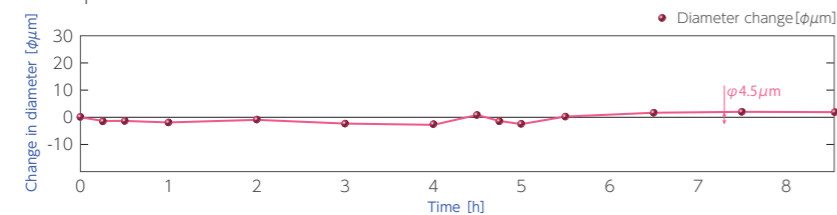

Roundness **0.5 μ m**

Spindle speed: 2,000min⁻¹

Material: BsBM(JIS)

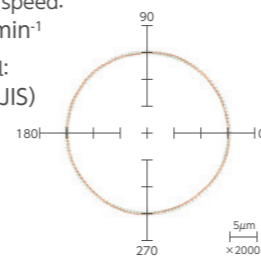

Data indicated in this catalogue are actual test results. Depending on changes in cutting conditions and/ or user environment, obtained results may be different.



Turning



Main Spindle

- Spindle motor **11/7.5kW**
- Cutting cross-section **2.8mm²/rev**
- Depth of cut **4mm (MAX.)**
- Feed **0.7mm/rev**
- O.D. Groove capability
Groove width **6mm**

Sub-Spindle(op.)

- Spindle motor **7.5/5.5kW**
- Cutting cross-section **1.98mm²/rev**
- Depth of cut **3mm (MAX.)**
- Feed **0.66mm/rev**
- O.D. groove end milling capability
Groove width **6mm**

Milling

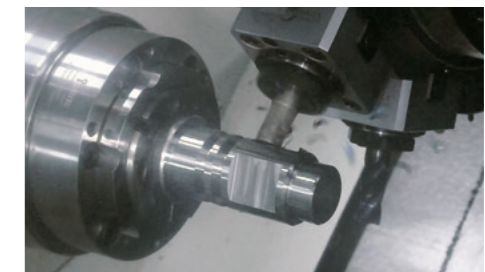

Milling

- Spindle motor **7.1/2.2kW**
- Speed **6,000min⁻¹**
- Y-axis travel **±40mm**
- Feed **0.7mm/rev**
- Material removal rate **16.8cc/min**
- Tool diameter **φ12mm**
(High speed end mill with 2 blades)
- Depth of cut **8mm**
- Feed **175mm/min**

※Depending on changes in cutting conditions and/ or user environment, obtained results may be different.

High Performance and Reliability

■ Bar Capacity $\phi 51\text{mm}$

Main Spindle **11/7.5kW**
5,000min⁻¹

■ Bar Capacity $\phi 42\text{mm}$

Sub Spindle **7.5/5.5kW**
6,000min⁻¹

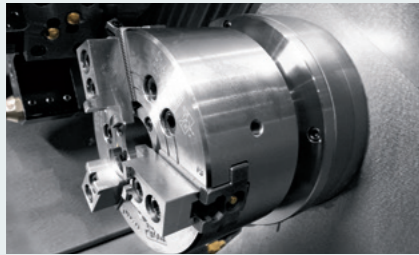

Milling and Y-Axis are standard equipment

■ Y-axis Travel 80mm($\pm 40\text{mm}$)

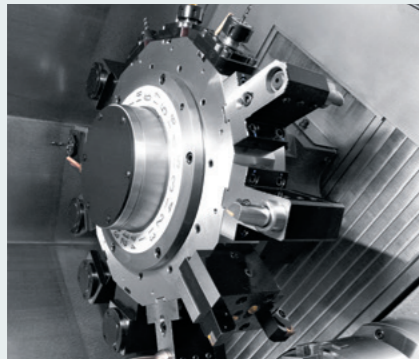

Milling Motor **7.1/2.2kW**
6,000min⁻¹

New Machine Bed Design

Chip disposal is improved.
Better accessibility during set-up.

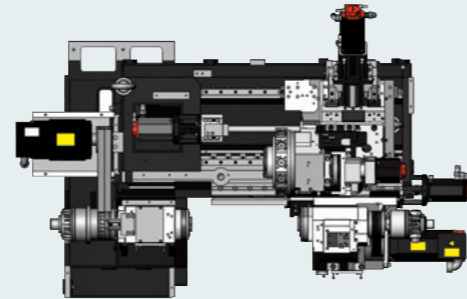

Compound Y-Axis Structure

Compound Y-Axis and low center of gravity, make the machine more robust.

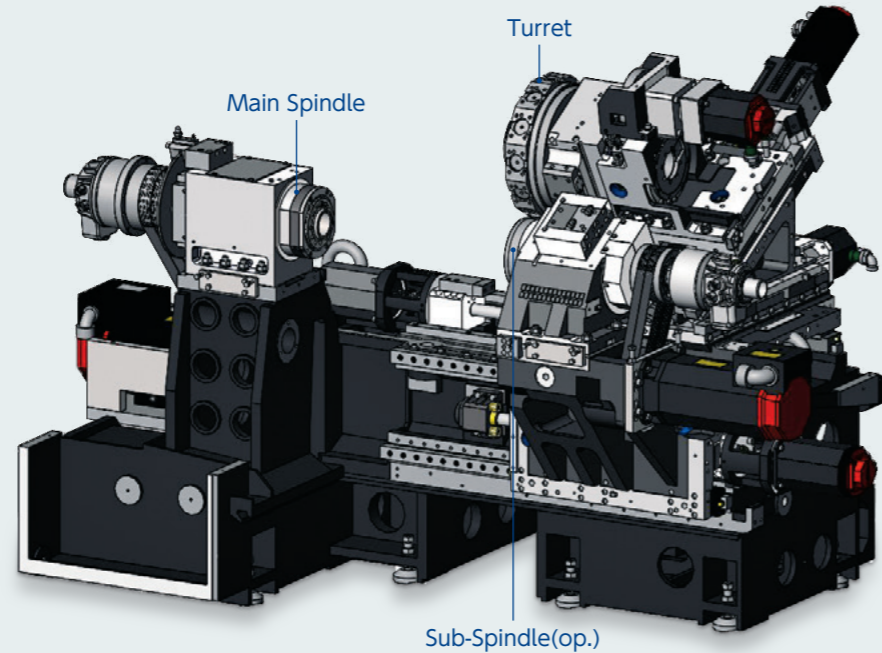

24 stations

12/24-Station Turret

- ▶ Number of tool stations : 12
- ▶ Max Number of tools : 24
- ▶ Number of indexing positions : 24
- ▶ Number of driven-tool stations : 12
- ▶ Driven-tool speed : 6,000min⁻¹
- ▶ Tool size (square shank/ round shank) : □20/ $\phi 25\text{mm}$
- ▶ Milling tool size : $\phi 1 \sim 14\text{mm}$

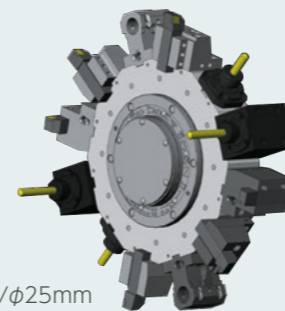

Floor space (Machine only)

*not including Motor area.

Standard specifications

L2,268mm × W1,700mm × H1,780mm



15-inch Color LCD

Built-in Parts Conveyor

Parts catcher A (PCA) and built-in parts conveyor are standard equipment of the sub-spindle specifications (op). Best package for Bar work.

※Built-in parts conveyor is not included without sub-spindle specifications.

Eco Friendly

Inverter type hydraulic unit with reduced power consumption. Furthermore, Lubricant oil recovery rate is improved.



Inverter type hydraulic unit

Power consumption reduction **21%^{※1}**

※1) This value may change depending on actual machining conditions.

Lubrication oil collection rate **100%^{※2}**

※2) Collection rate is 75% in case of sub-spindle specifications

Various Options to Meet Customers Needs. Total Provider of Peripheral Equipment.

Whether it is machine set up, cutting chip management, higher efficiency or improved productivity, Nakamura-Tome offers top class peripheral equipment, which boosts the performance of our Multitasking Machines. As a total solution provider with numerous achievements, Nakamura-Tome offers complete solutions, including Multitasking Machines complemented with a variety of peripheral equipment.



※ SC-100(Mata-Bei Specifications)



Mata-Bei (Sub-Spindle)



Tailstock

and many others ...
For not Listed Items, please contact your Nakamura-Tome representative.



Parts Catcher A+Built-in conveyor. *Standard for Sub-Spindle Specs.

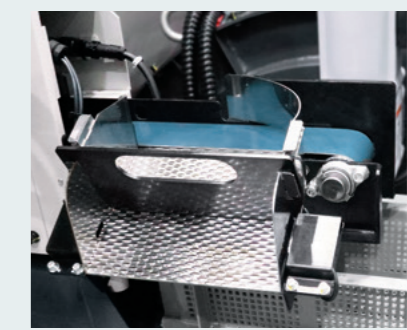

Built-in conveyor chute



Han-Bei (In-process measuring system)



Chip conveyor



Tool setter



Signal tower



Coolant pump



Oil skimmer

Full Operator Support : User-Friendly and Highly Reliable

Jig-less!
Setup-less!
Skill-less!

This essential function for
multitasking machines
is standard.



Main Features

- Standard
- NT Work Navigator
- Airbag (Overload detection)
- Advanced NT NURSE
- NT Smart Sign
- Digital Chuck Interlock
- Option
- NT Manual Guide i (LUCK-BEI II)



Digital Chuck Interlock

Set the detection position of open end and closed end of chuck arbitrarily. The chuck open / close position is set on the NT NURSE screen. Setup time and machining cycle time are reduced.

Airbag (Overload detection)

Compared to other machines, Nakamura-Tome machine will not break after the slightest collision. The "Airbag Function" minimizes the damage that may occur during a collision.

If a machine collision occurs, there is good reason to be assured: Airbag !

Barrier?
Even with barrier
function, machine
collisions may
occur

When the machine collision occurs,
there is no reason to panic.

The Airbag (Overload detection) of the machine tool greatly reduces the impact of a collision, and protects the machine.

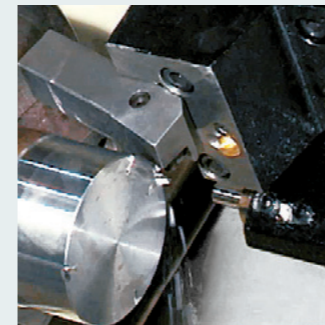

Without Airbag

Machine will not be stop immediately. The slide continues to move even after collision.

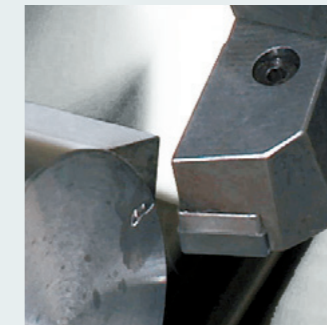

With Airbag

Retraction within 0.001 sec

Crash !
Within 1 milliseconds after the crash, servo motor-feeding direction is reversed and the machine stops in EMG mode.



▲Video

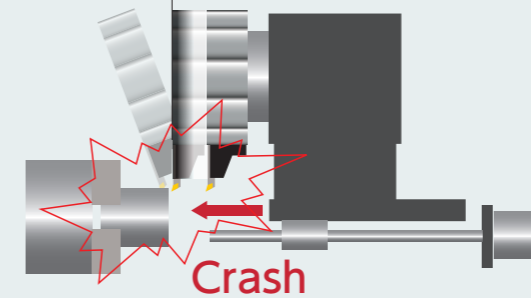

* This feature does not mean zero impact

NT Work Navigator



A new upgrade makes it possible to navigate with the X and Y-axes. Many parts with irregular outer surfaces, requiring coordinate recognition with X or Y-Axis, become within the range of NT Work Navigator.

Advanced
NT Work
Navigator !

No fixtures
required

Machining parts with non-round shapes, such as forgings or castings requires that the raw part coordinates be recognized by the CNC control. In order to achieve this without requiring extra cost or additional options, the NT Navigator is used. It works just by touching the part with a simple inexpensive probe (mostly round bar mounted on a tool holder) and using the torque control feature of the servo-motor, which is to record required coordinates in the CNC. The NT Navigator is a cost cutting feature in multitasking machines, eliminating the need for positioning fixtures and special clamping devices.

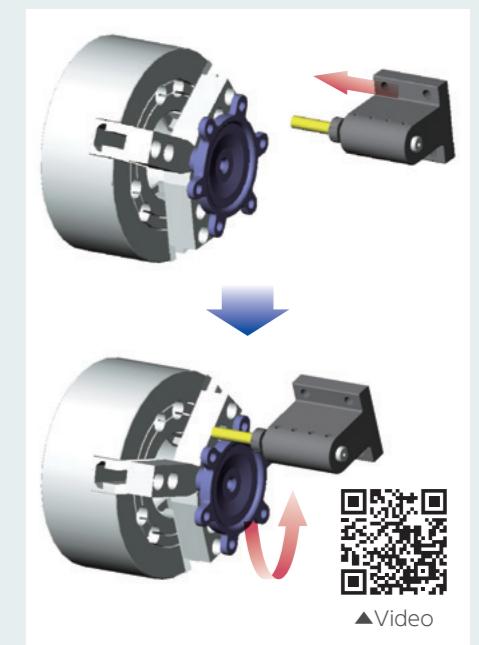

▲Video

Featuring Functions to Make Efficient Programs, Faster

Advanced NT NURSE

All-in-one software!

NT Nurse is software that provides the operator with user-friendly support for operation, programming and production on the machine. Among vital features are phase recognition (a must for multitasking), direct chucking to prevent positioning error during transfer, and perfect synchronization of the

left and right hand spindles. Among other features, are the load monitor for detecting tool wear and tool breakage, tool life management, operation condition monitoring, in addition to many other features to simplify programming, set up, operation and production, all offered in one single package.

*Depending on machine specifications, some functions are not available.

Useful functions

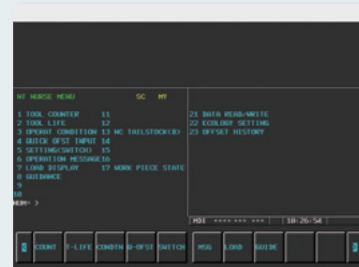

Menu Screen

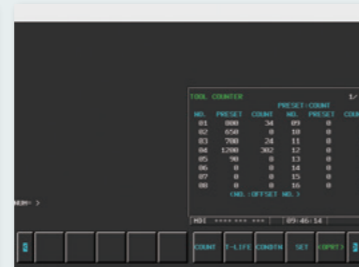

Tool Counter

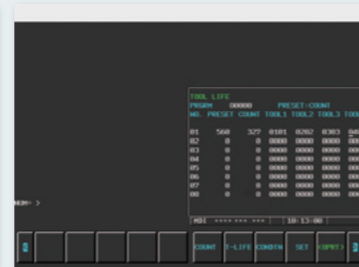

Tool Life

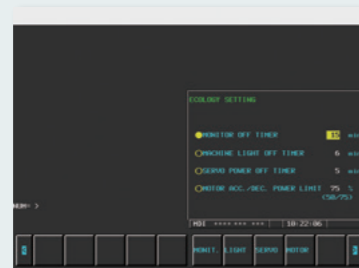

Energy Saving

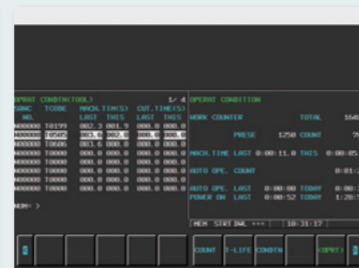

Operation Condition of each Tool

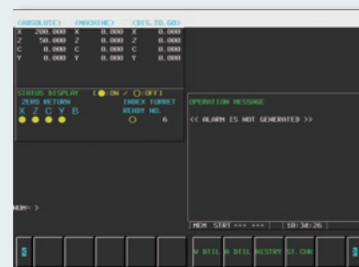

Operation Message



Quick Offset



NT NURSE Call Button

NT Manual Guide i (LUCK-BEI II) — Option

A programming guidance system with the ability to generate NC programs (ISO/EIA G-code programs) easily. Processes created in conversational mode can be cut, copied or moved ensuring flexibility. Additionally, several cycles such as part-transfer cycle, requiring waiting M-codes, are readily made with the "NC program editing support function". The "NC program simulation function" can be used to check created-programs by tool-path simulation or solid-model animation.

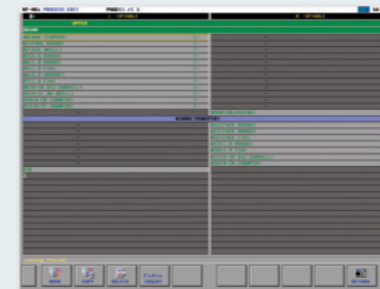

▲ Process Editing Function

NT Manual Guide i automatically recognizes each process and lists all processes. Operator can easily change and optimize the program by moving processes, copying processes or adding waiting-functions.



▲ Fixed-form sentence function

NT Manual Guide i contains more than 300 types of fixed form sentences. Operator can select these fixed form sentences for the program from a menu screen.

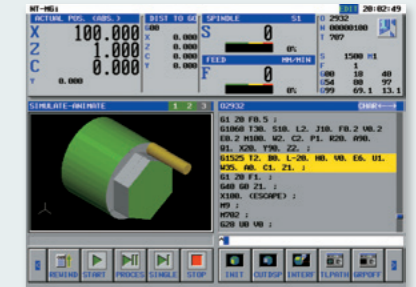

▲ Simulation

Accurate simulation of turning and milling operations using a 3D solid model.

By introducing the "automatic cutting condition setting function", the number of key strokes required to make a program were reduced by 50% reduced, compared with the previous NT-Manual guide version.

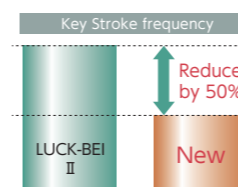

Automatic Cutting-Condition Setting Function

By setting the material type and required surface roughness, cutting conditions are automatically generated. These can be also changed depending on customer's experience.

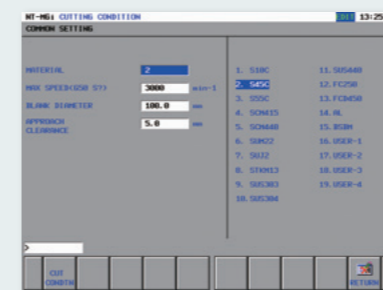
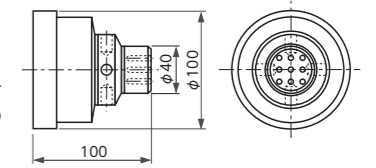

By selecting the material, cutting conditions B are automatically input.



By setting the surface roughness, machining conditions are automatically input

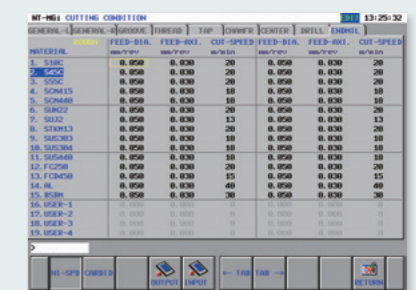

Cutting conditions. End mill

Torque/Output Chart

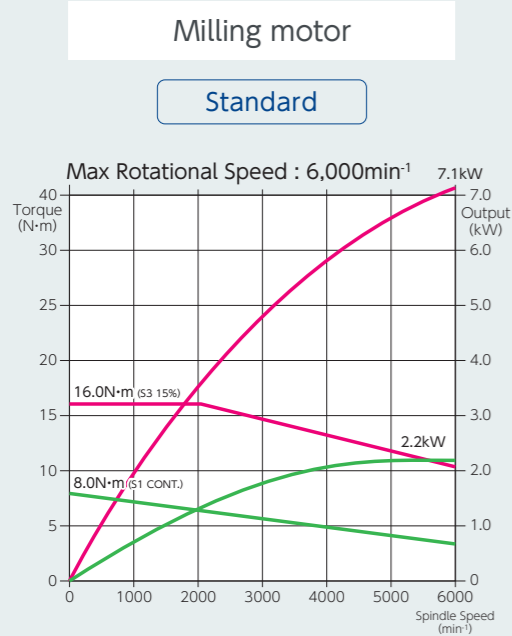
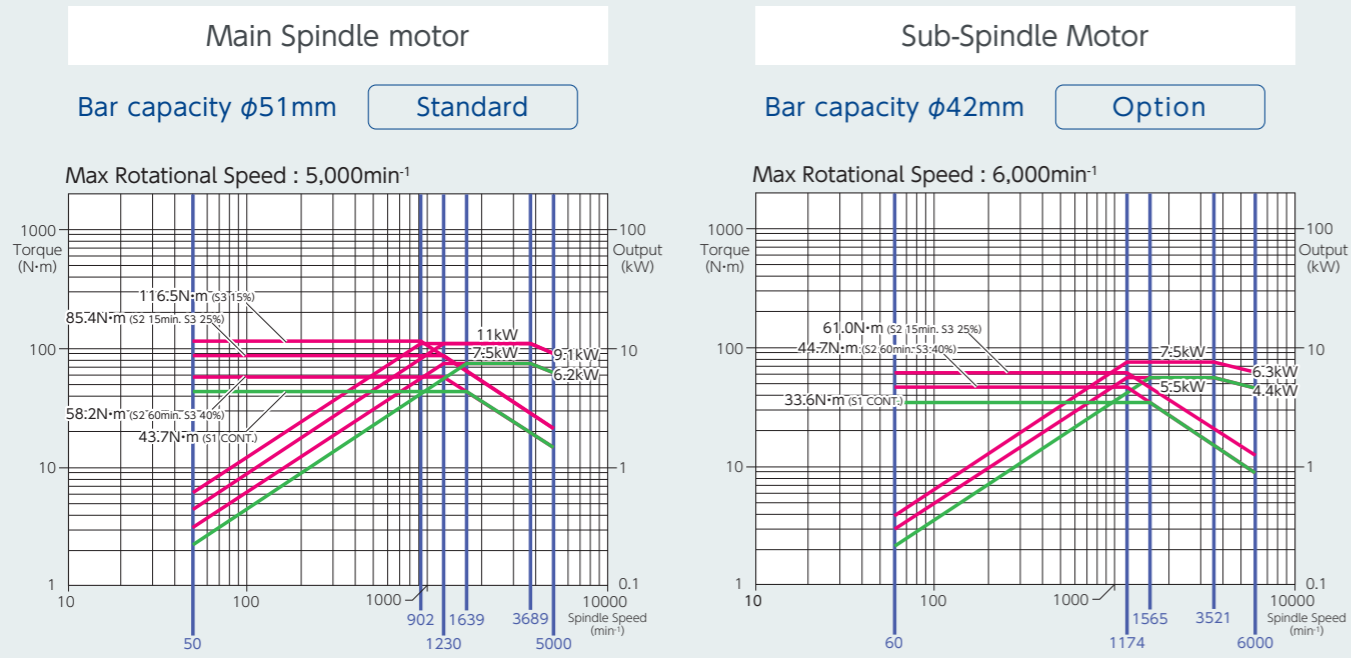

Tool Interference

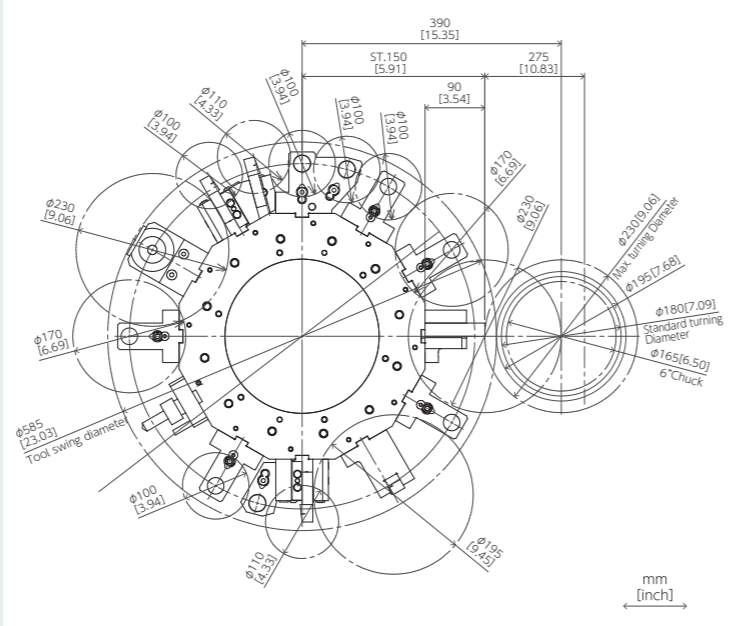

Tooling System

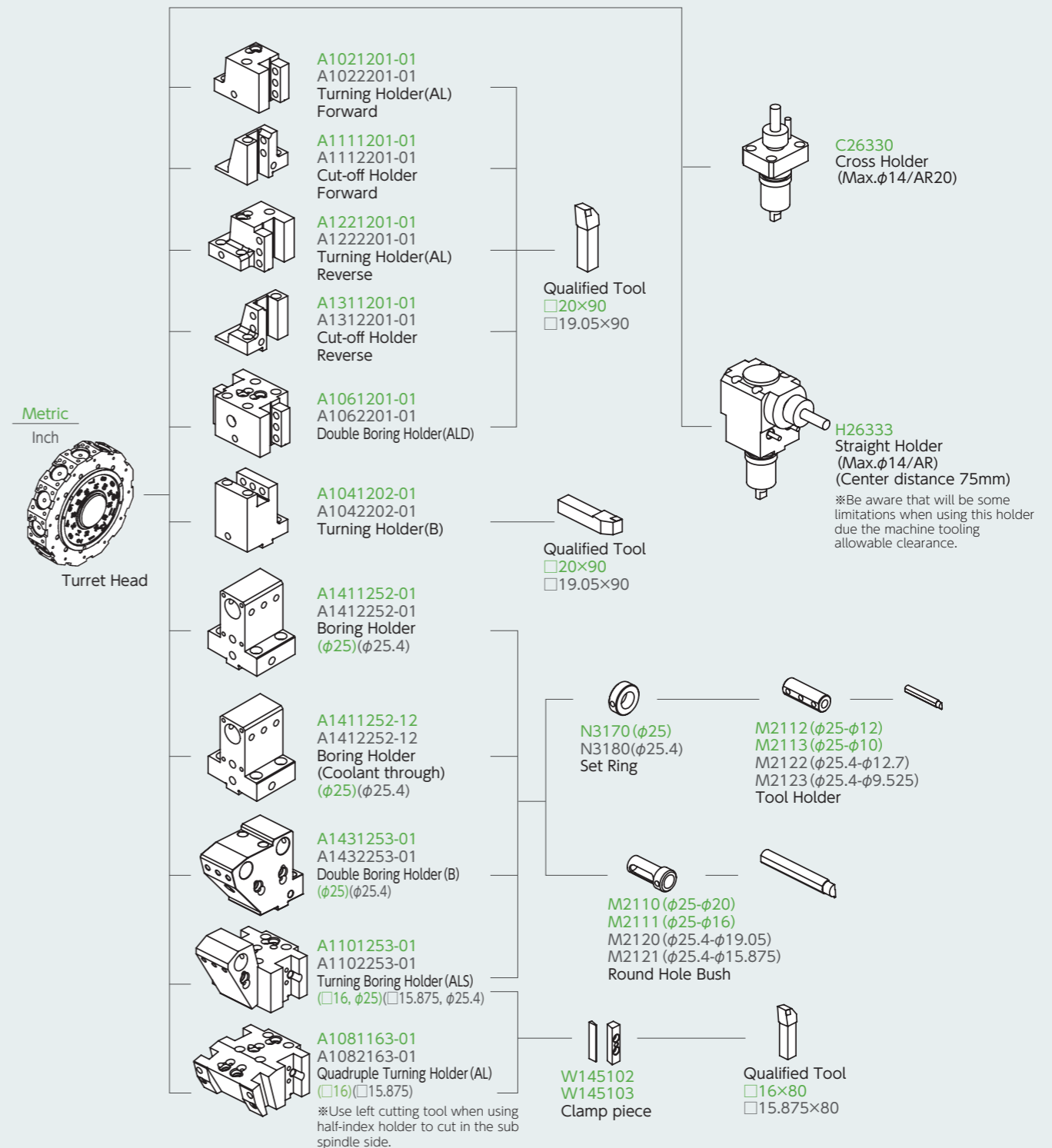

Travel Range

Standard Specifications

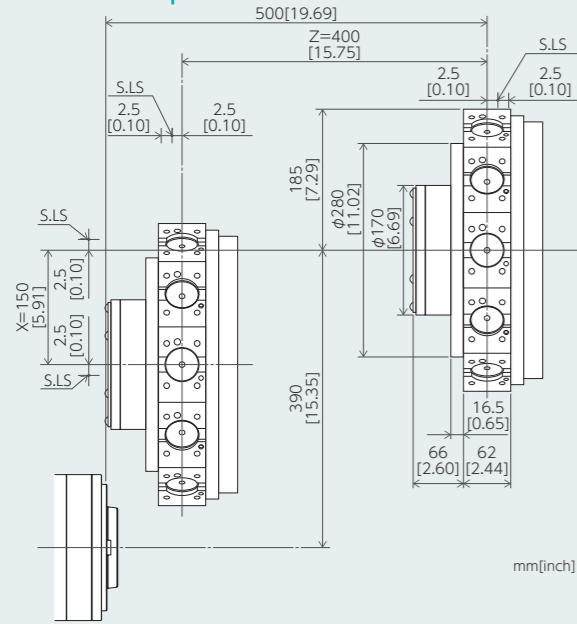

Y-Axis slide travel

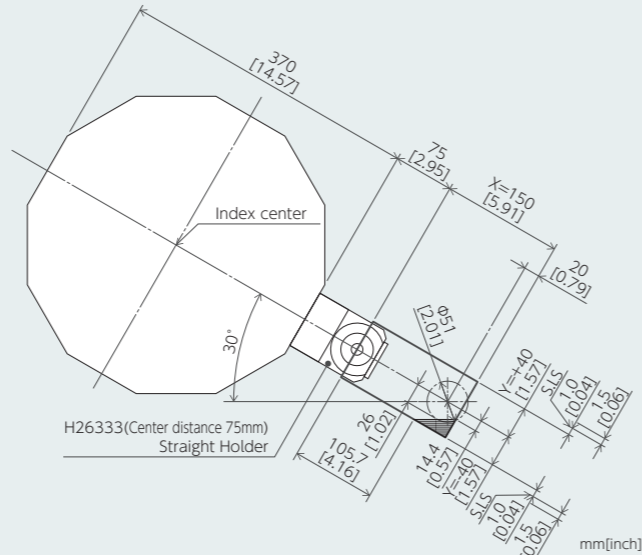

- The shaded area is interlock area.
- Depending on mounting station, some restrictions apply.

Tailstock Specifications

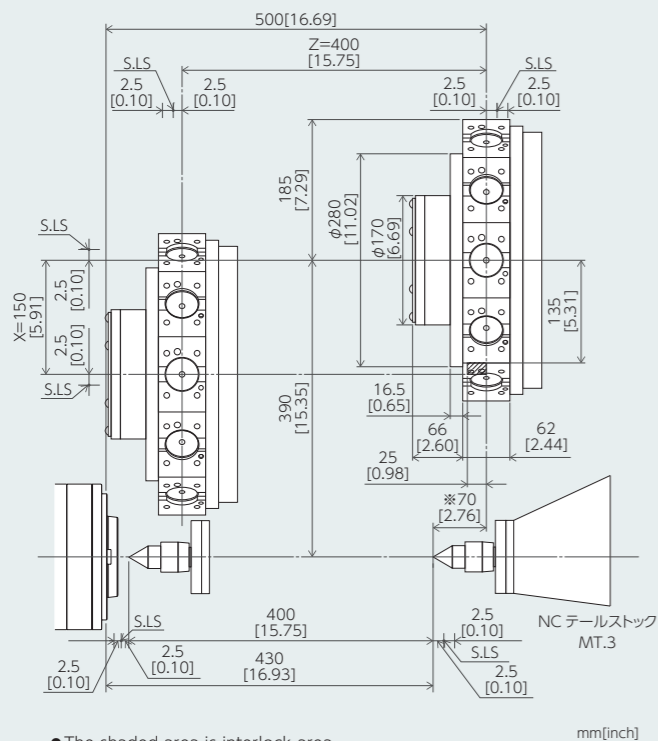

- The shaded area is interlock area.
- Interlock area for Z-axis direction depends on the transfer of tailstock.
- Tailstock cannot approach more than 70mm; relative distance with Z-axis. (marked as ※)

Mata-Bei Specifications (Sub-Spindle)

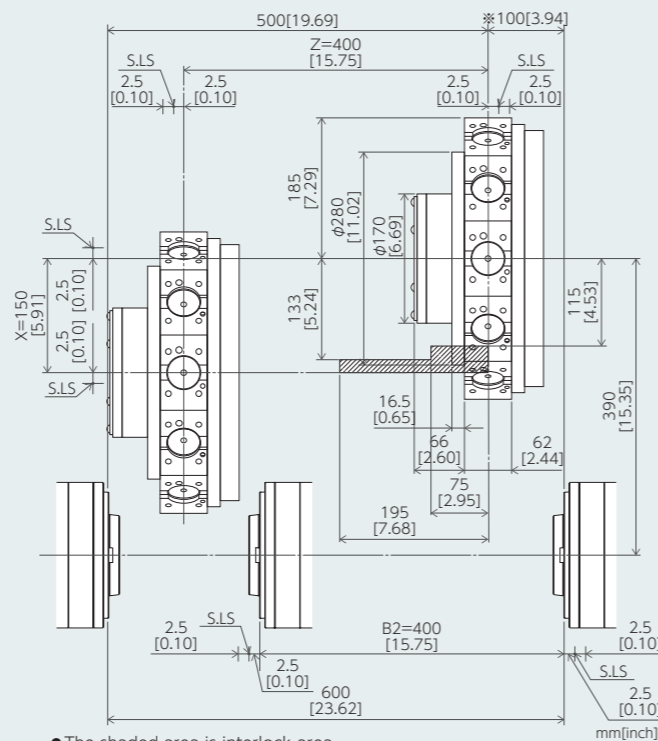

- The shaded area is interlock area.
- Interlock area for Z-axis direction depends on the transfer of B2-axis.
- B2-axis cannot approach less than 100mm; relative distance with Z-axis. (marked as ※)

Machine Dimensions

Standard / Tailstock Specifications

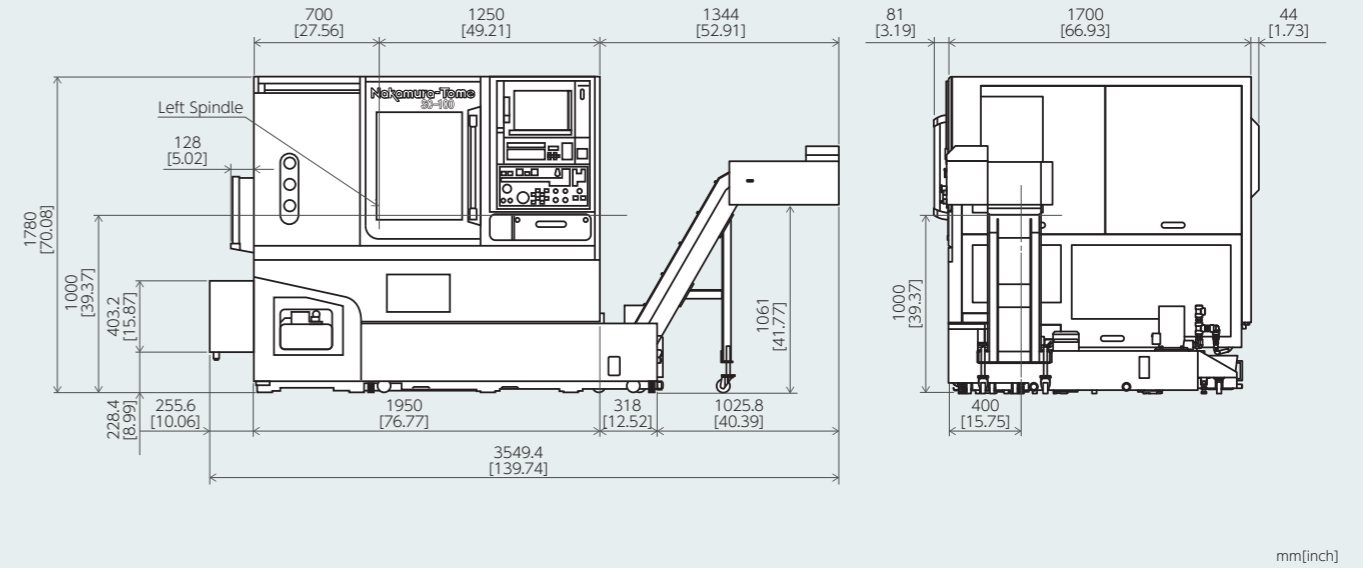

Mata-Bei Specifications (Sub-Spindle)

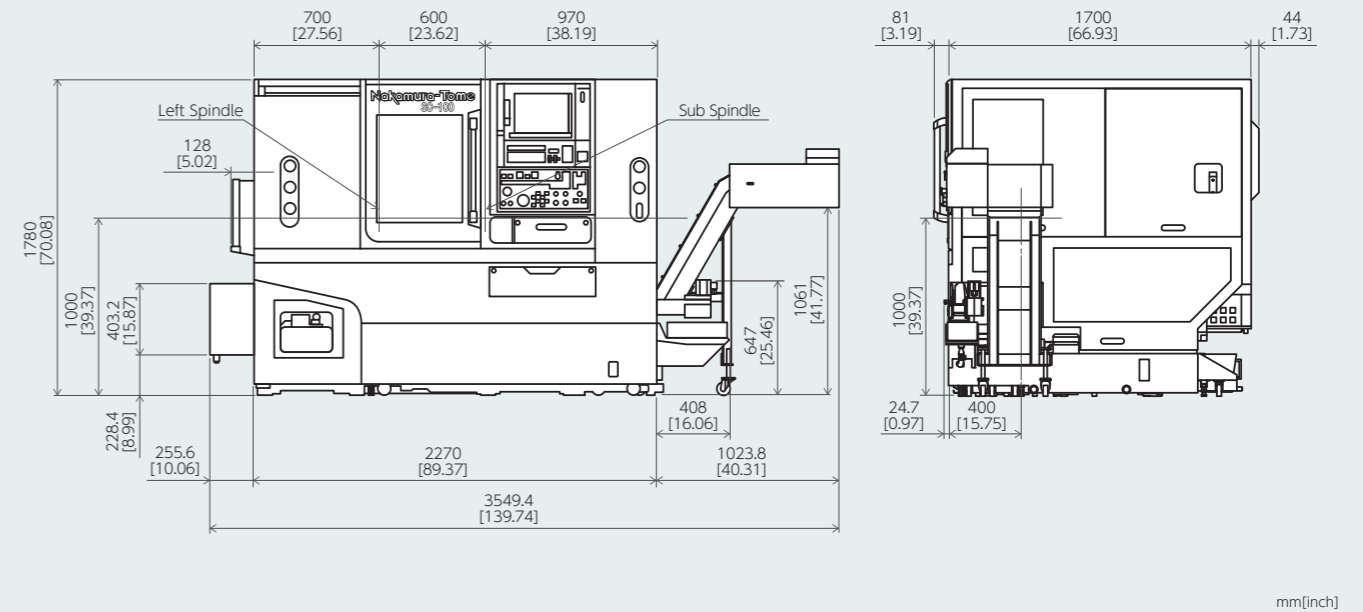

■ Capacity

Max.turning diameter	230mm	
Standard turning diameter	180mm	
Max.turning length	Standard / Sub-Spindle	400mm
	Tailstock	300mm
Distance between spindle face	Max.600mm / min.200mm	
Distance between spindle face and quill edge	430mm	
Bar capacity(L/R)	φ51mm / φ42mm	
Chuck size (L/R)	6" / 5"(6")	

■ Axis Travel/ Rapid Feed

Slide travel X	150mm
Slide travel Z	400mm
Slide travel Y	±40mm
Rapid feed X	20m/min
Rapid feed Z	36m/min
Rapid feed Y	6m/min

■ Main Spindle φ51mm

Spindle speed	5,000min ⁻¹
Spindle speed range	Stepless
Spindle nose	A2-5
Hole through spindle	63mm
I.D. of front bearing	90mm
Hole through draw tube	52mm

■ Sub Spindle(op.) φ42mm

Spindle speed	6,000min ⁻¹
Spindle speed range	Stepless
Spindle nose	A2-5
Hole through spindle	56mm
I. D.of front bearing	80mm
Hole through draw tube	43mm

■ C axis

Least input increment	0.001°
Least command increment	0.001°
Rapid index speed	600min ⁻¹
Cutting feed rate	1 ~ 4,800° /min
C-axis clamp	Disk clamp
C-axis connecting time	1.5sec.

■ Turret

Type of turret head	Dodecagonal drum turret
Number of tool stations	12 (max.24)
Number of indexing positions	24
Tool size (square shank)	□20mm (12st) / □16mm (24st)
Tool size (round shank)	φ25mm

■ Driven Tools

Driven system	Individual rotation
Speed	6,000min ⁻¹
Speed range	Stepless
Number of driven-tool stations	12
Holder type and Tool size	Straight holder φ1mm ~ φ14mm
	Cross Holder φ1mm ~ φ14mm

■ Drive motor power

L - spindle	11/7.5kW
R - spindle	7.5/5.5kW
Milling Spindle	7.1/2.2kW

■ General

Height	1,780mm	
Floor space (L × W)	Standard	2,523.6mm × 1,825mm
	Sub-spindle	2,933.6mm × 1,825mm
	Tailstock	2,523.6mm × 1,825mm
Machine weight	Standard	4,500kg
	Sub-spindle / Tailstock	5,000kg

■ Power supply

Power supply	17.4kVA(20.2kVA) (Standard)
	22.0kVA(24.8kVA) (Sub spindle)

● Safety quality specifications

Various interlocks, such safety fences, auto extinguisher devices, and other safety related equipment may be required. These have to be selected during the configuration of the machine.

① Safety devices include electromagnetic door lock, chuck interlock, hydraulic pressure switch, air pressure switch, short circuit breaker and quill interlock. (Door interlock and chuck interlock are standard equipment.)

② In case of automation, various safety fences may be required, such as work stocker safety fences, robot safety fences, ...etc.

During the configuration of machine specifications, please discuss these requirements with the Nakamura-Tome machine sales representative.

● Precautions on the use of cutting fluids and lubricating oils

Some types of cutting fluids (coolant) are harmful to machine components, causing damages such as peeling of paint, cracking of resin, expanding of rubber, corrosion and rust build up on aluminum and copper. To avoid causing damage to the machine, never use synthetic coolants, or any coolants containing chlorine. In addition, never use coolants and lubricating oils which contain organic solvents such as butane, pentane, hexane and octane.

Machine warranty terms are void for any claims or damage arising from the use of inappropriate cutting fluids or lubricating oils.

■ Items

Control Type	Nakamura-Tome FANUC (0i-TF)
--------------	-----------------------------

■ Controlled axes

Controlled axes	4 axes : X,Z,C,Y
-----------------	------------------

■ Input command

Least input increment	0.001mm/0.0001inch (X in diameter) .0001°
Least command increment	X : 0.0005mm / Z, Y : 0.001mm / C : 0.001°
Max. programmable dimension	±999999.999mm/ ±39370.0787in, ±999999.999°
Absolute / incremental programming	X, Z, C, Y / U, W, H, V
Decimal input	Standard
Inch / Metric conversion	G20 / G21
programmable date input	G10

■ Feed function

Cutting feed	Feed mm/min 1 ~ 8000mm/min, 0.01 ~ 314inch/min X-axis, Z-axis (1 ~ 4800mm/min, 0.01 ~ 188inch/min) Y-axis 1 ~ 6000mm/min, 0.01 ~ 236inch/min (1 ~ 4800mm/min 0.01 ~ 188inch/min) C-axis 1 ~ 4800° /min
	Feed mm/rev 0.0001 ~ 500.0000mm/rev 0.000001 ~ 9.999999inch/rev
	The maximum cutting feed rate is the value in AI contour control mode. Also activated with G316. The values in parentheses are normal values.
Dwell	G04
Feed per minute/ Feed per revolution	G98 / G99
Thread cutting	G32F
Thread cutting retract	Standard
Continuous thread cutting	Standard
Variable lead threading	G34
Handle feed	Manual pulse generator 0.001/0.01/0.1mm (per pulse)
Automatic acceleration/ deceleration	Standard
linear accel. decel. after cutting feed interpolation	Standard
Rapid feed override	F0/25/50/100% (NT setting display 0 ~ 100%, 10% per step)
Cutting feed rate override	0 ~ 150% (each 10%)
AI Contouring control I	G5.1
spindle override	50%~ 120% Set every 10%

■ Program memory

Part program storage length	512Kbyte (Total 1280m / Standard) 1Mbyte (Total 2560m / Sub spindle) 2Mbyte (Total 5120m / op.)
Parts program editing	delete, insert, change
Program number search	Standard
Sequence number search	Standard
Address search	Standard
Number of registerable programs (Part program storage length / Standard or Sub spindle)	400(512Kbyte / Standard), 800(1Mbyte / Sub spindle) 400 (2Mbyte / Standard)(op.) 800 (2Mbyte / Sub spindle)(op.) 1000 (512Kbyte, 2Mbyte / Standard)(op.) 1000 (1Mbyte, 2Mbyte / Sub spindle)(op.)
Program storage memory	Backed up by battery
Multiple program simultaneous editing	Standard
DNC operation through memory card	Standard (not including memory card)
Extended parts program editing	Standard

■ Operation and display

Display	15-Inch color LCD
Keyboard	QWERTY keyboard

■ Programming assist function

Circular interpolation R programming	Standard
Direct drawing dimension programming or Chamfering/Corner R	Standard (switched by setting parameter)
Canned cycle	G90, G92, G94
Multiple repetitive canned cycle	G70 ~ G76
Multiple repetitive canned cycle II	G71,G72
Canned cycle for drilling	G80 ~ G89
Sub program	Standard
Custom macro	Standard (#100 ~ #149, #500 ~ #549)
Addition to custom macro common variables	Standard (After addition #100 ~ #199, #500 ~ #999)
FS10/11 tape format	Standard
Luck-bei II / NT Manual Guide i	Option
Abnormal load detection function	Standard
NT Work navigator	Standard (not including contact bar)
NT NURSE	Standard

■ Mechanical support

Rigid tap	Standard
Spindle orientation	Standard (any angle is available within 360° ,Control unit: 0.088°)
Driven-Tool rigid tapping	Standard
Polygon function	Standard

■ ECO function

Servo motor off	Standard (selected on energy saving setting screen)
Control of motor output during acceleration and deceleration	Standard (selected on energy saving setting screen)
G code for servo motor energy-saving acceleration and deceleration	G356/G357
Fan motor stop	Standard(Fan motor on/off is controlled by detecting temperature of spindle motor)
Auto machine-light off	Standard(selected on energy saving setting display)
Auto monitor off	Standard(selected on energy saving setting display)



NAKAMURA-TOME PRECISION INDUSTRY CO., LTD.

<http://www.nakamura-tome.co.jp>

Netsuno 15, Hakusan city, Ishikawa, 920-2195 Japan
Phone : +81 76 273 8100 Fax : +81 76 273 4312
E-mail : nt-jpn@nakamura-tome.co.jp

* This catalog was published in April 2020.
Specifications, illustrations and data given
herein are subject to change without notice.

* The products in this catalog are controlled
based on Japan's "Foreign Exchange and
Foreign Trade Law". The export of the
products are subject to an export license by
the Japanese government.