

JX-200

NAKAMURA-TOME
PRECISION INDUSTRY CO.,LTD.

Change the IMPOSSIBLE
to POSSIBLE

Innovative
Technology

~ Creating new values ~

JX-200

Ultra-modern 6 to 8-inch chuck multitasking machine. With tool spindle and a lower turret equipped with a standard Y-axis featuring the "NT Smart Cube", the shortest tool spindle in its class. The machining area can be used effectively, thus covering a wide range of machining needs. Additionally, a full range of Nakamura-Tome user-friendly software is available.

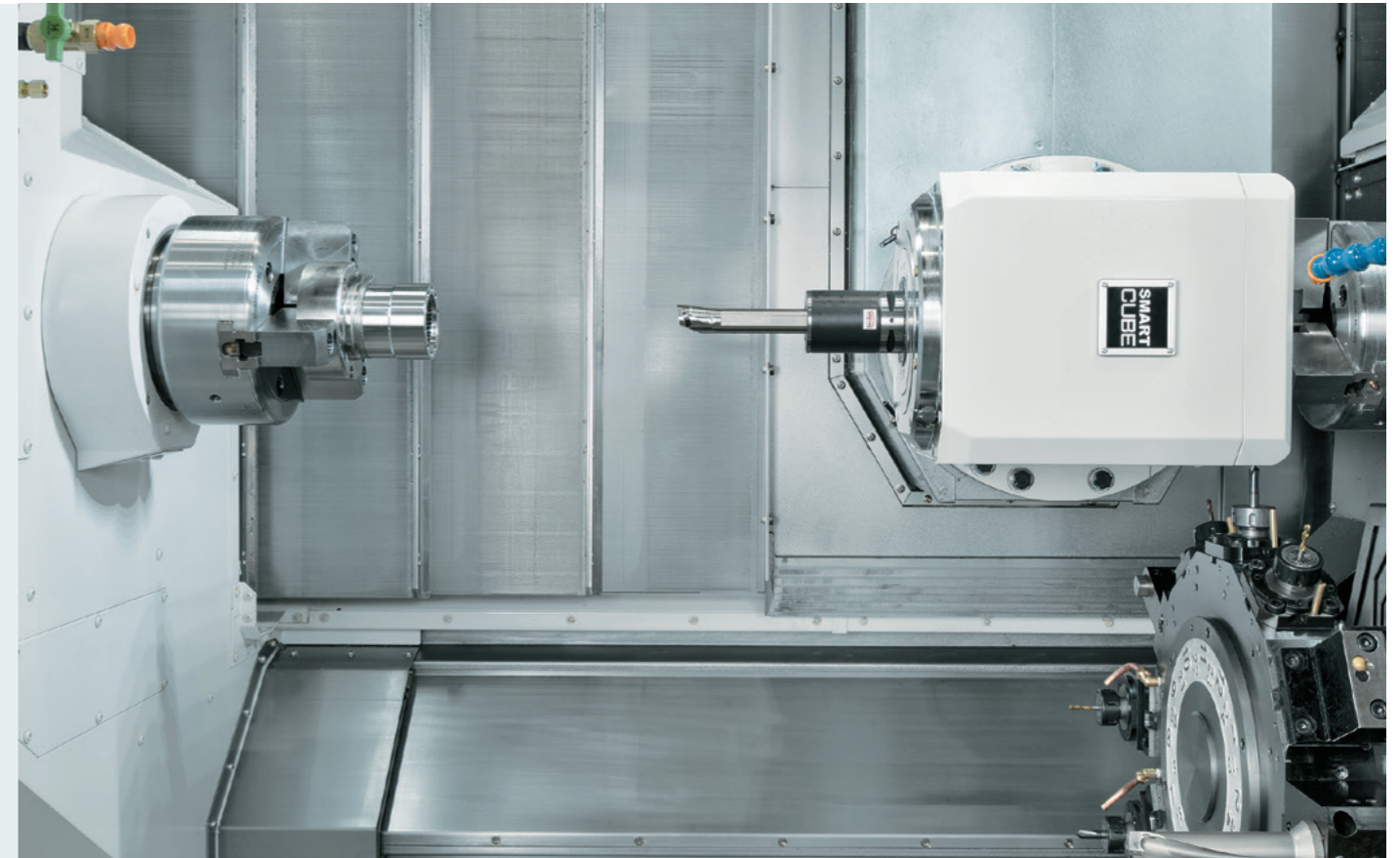

Change the IMPOSSIBLE to POSSIBLE

The world's shortest tool spindle in its class, "NT Smart Cube" allows for more effective use of its large machining area. By combining the Lower turret, various machining operations can be supported, such as simultaneous machining with L/R spindles, simultaneous machining with Upper and Lower turrets, and center support on the Lower turret. With the ability to handle a workpiece covering the entire volume zone and a flexible unit configuration that enables any types of process. These are some examples of the various operations that this machine can do.

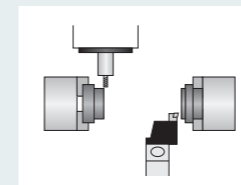

Flexible machining with L/R spindles

Flexible machining with L/R spindles to reduce the cycle time.

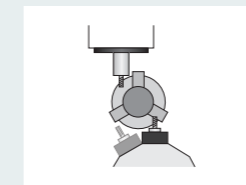

Simultaneous Y-axis vertical machining

Wide variety of milling operations, thanks to its Y-axis travel of $\pm 105\text{mm}$ on the tool spindle and $\pm 35\text{mm}$ on the lower turret.

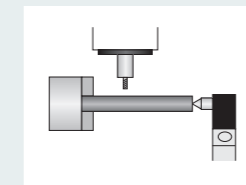

Turret Center-support

The center support on the Lower turret is ideal for long workpieces.

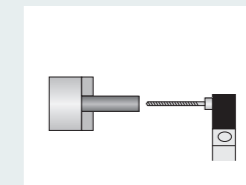

Long drill machining

Enables the use of long drills that do not fit in the ATC magazine.

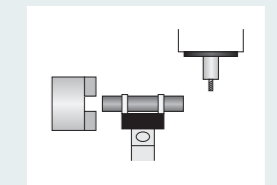

Semi-automatic

Loading/Unloading workpieces by the work rest on the turret.

POSSIBLE to perform several different processes with just one machine!

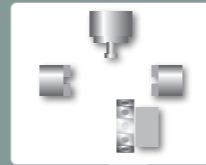
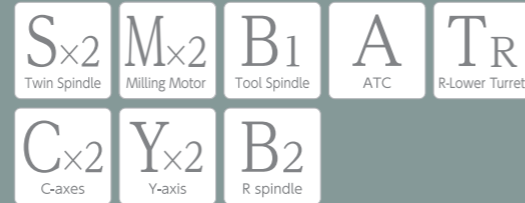

- "NT Smart Cube" is one of the world's shortest tool spindles in its class
- ATC tool spindle motor 15/11kW Tool spindle speed 12,000min⁻¹ (op. 18,000min⁻¹)
- The number of ATC tools:80 (op. 40,120)
- 5.5/3.7kW milling motor on the lower turret rotation speed 6,000min⁻¹ (op. 8,000min⁻¹)
- Increased stability thanks to a heavy-duty column structure
- Floor space 2,925mm ×5,250mm(including standard coolant tank)
- Extensive variety of Nakamura-Tome user-friendly software



Tool spindle swings from -95° to +95°, and the Lower turret with Y-axis flexibly handles small to large diameter workpieces, long workpieces, and complex shapes.

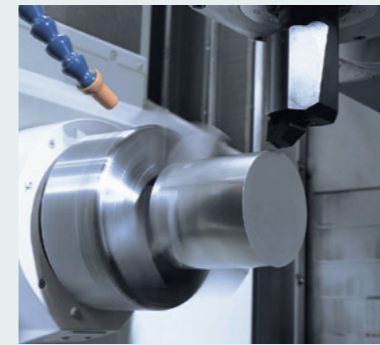

L-spindle

- Spindle motor
15/11kW
18.5/15kW(op.)
- Spindle speed
4,500min⁻¹
3,500min⁻¹(op.)

R-spindle

- Spindle motor
11/7.5kW
15/11kW(op.)
- Spindle speed
6,000min⁻¹
4,500min⁻¹(op.)

Turning (Tool spindle)

Common cutting condition

- Material **S45C**
- Cutting speed **120m/min**

- Cutting cross section
3.6mm²
- Depth of cut **6mm**
- Feed **0.6mm/rev**

- Cutting cross section
2.65mm²
- Depth of cut **5mm**
- Feed **0.53mm/rev**

- Material **S45C**
- Cutting speed **100m/min**

- Groove width **8mm**
- Feed **0.1mm/rev**

- Groove width **5mm**
- Feed **0.1mm/rev**

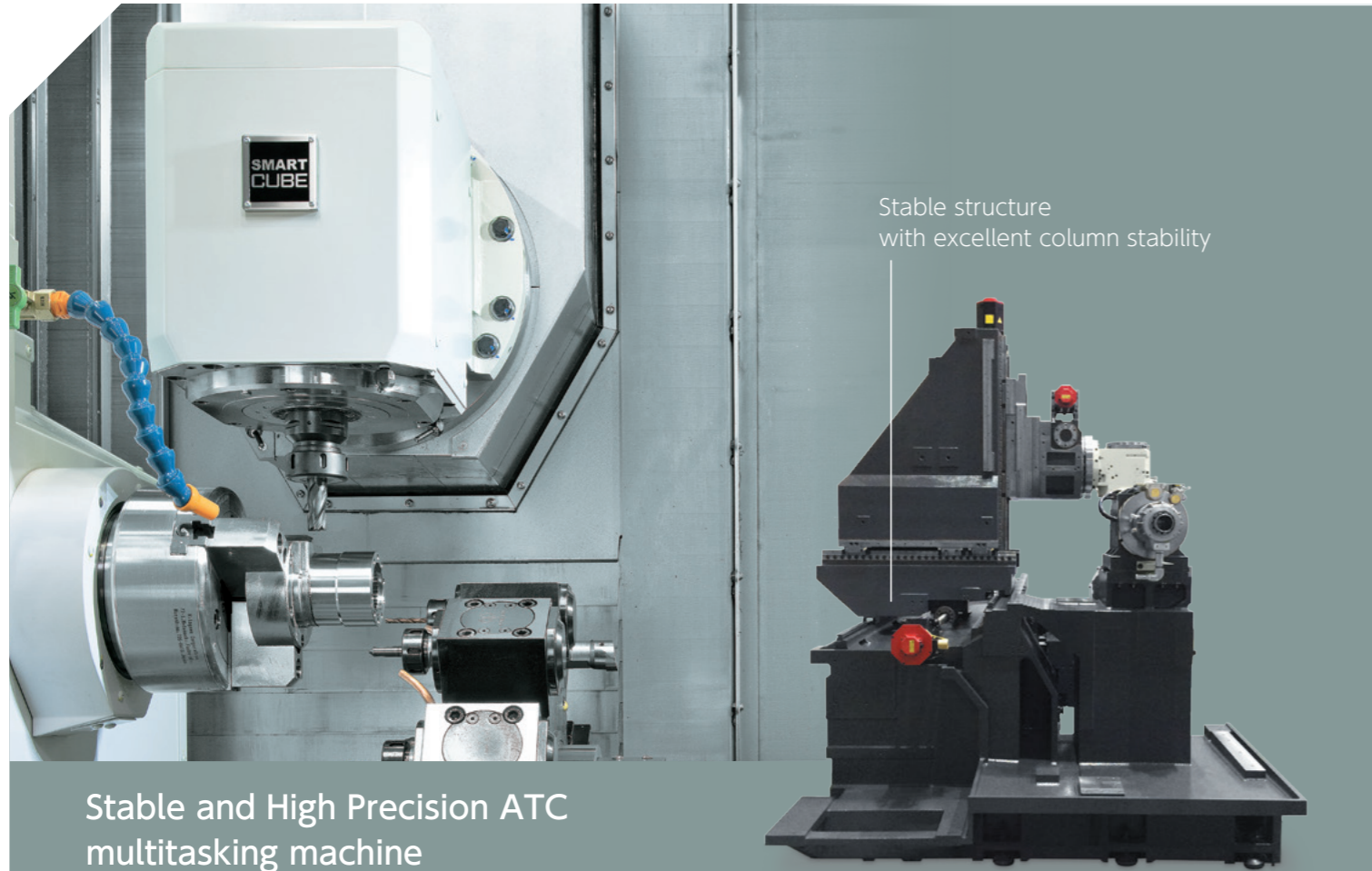

Stable and High Precision ATC multitasking machine

The JX-200 was developed on the concept of ATC multi-tasking machine that can stably process good-quality products with good precision. Since a tool spindle column is allocated vertically to a horizontal bed and the center of gravity is designed in an optimal position, the machine has a strong structure against load from any direction. Therefore, the machine preserves stability and can process even difficult to machine materials or handle heavy cutting with accuracy. Moreover, to minimize the impact of distortion caused by heat, the frame structure was also redesigned. In combination with the thermal growth compensation system "NT Thermo Navigator AI", the machine will achieve high-precision machining.

Nakamura-Tome multitasking machines are not only known for their high machining capabilities but are also known for "high rigidity" and "high precision".

■ Thermal displacement amount Upper **7.3 μ m** Lower **4.8 μ m**

* Actual Values shown here are obtained when ambient temperature conditions are met.

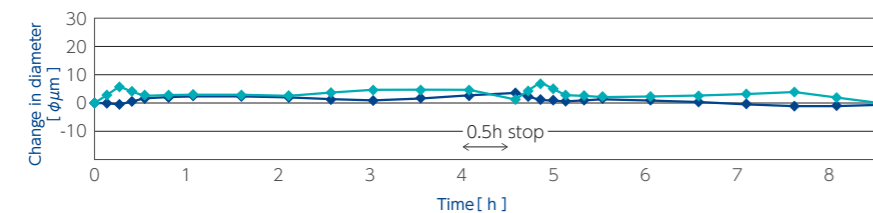

■ Roundness **0.36 μ m**

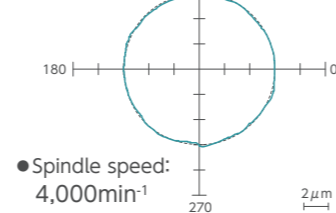

● Spindle speed: 4,000min⁻¹

● Material:BsBM(JIS)

Contour machining accuracy

X-Y plane

■ Roundness **1.9 μ m**

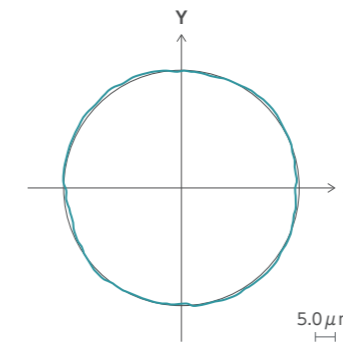

Y-Z plane

■ Roundness **1.9 μ m**

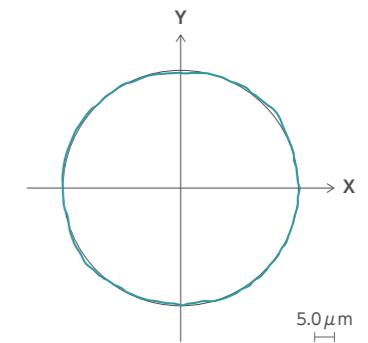

Transferring Accuracy

■ Coaxiality **φ6.0 μ m**
(Required accuracy:φ10 μ m)

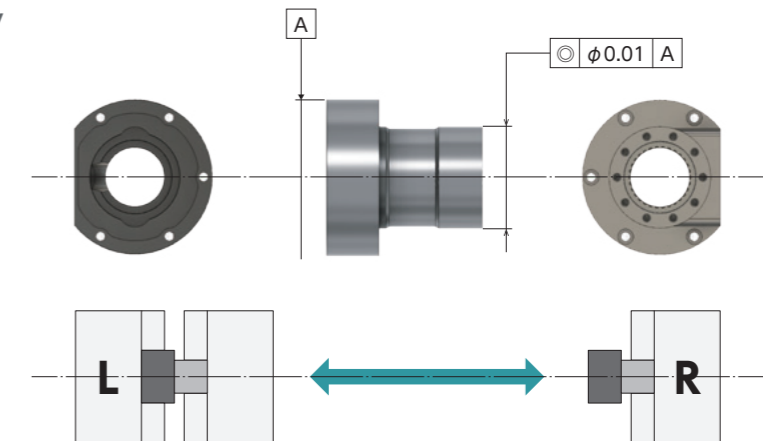

Turning surface roughness

■ Surface roughness (Rmax) **0.91 μ m**

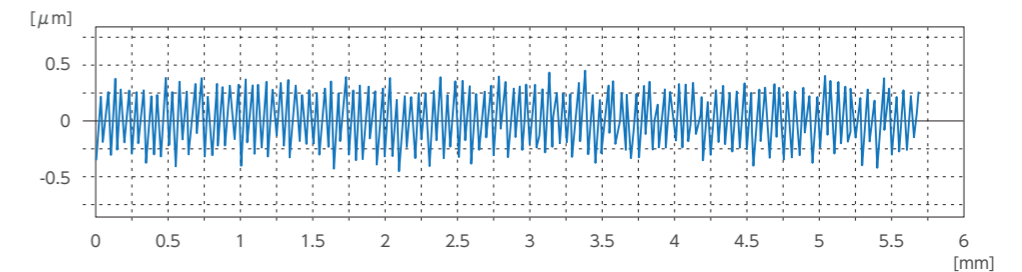

* The actual measured values shown in this catalog are for reference only and may differ depending on cutting conditions and specifications.



The world's shortest tool spindle in its class*

NT Smart Cube

Tool Spindle (NT Smart Cube)

- Length **349.1mm**
* The length is 428.6mm in case the tool spindle speed is 18,000min⁻¹
- Y-axis slide travel **±105mm**
- 15/11kW**
- Tool spindle motor **12,000min⁻¹**
18,000min⁻¹ (op.)

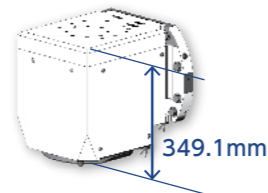

Large machining area

The world's shortest tool spindle in its class! Thanks to the ultra-compact size of the Tool Spindle, the interference is reduced, and it ensures a larger machining area.

* Based on our survey in the multitasking machine market

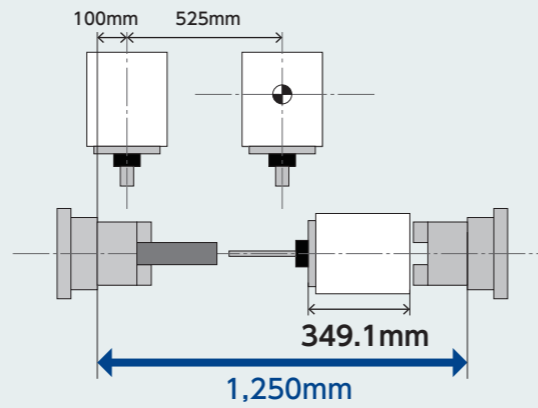

144 stations

Up to 144 tools available!

In addition to 120 ATC tools(op.) for the Tool Spindle, 24 tools(half index) can be mounted on the Lower Turret.

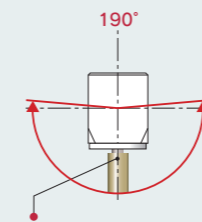

Max.tool diameter / Without adjacent tool : $\phi 90 / \phi 130\text{mm}$
Max.tool length : 300mm



ATC Maintenance Navigator

In addition to information about the ATC status and position of the Tool Changer arm, the step-by-step ATC recovery guidance screen ensures fast ATC recovery and shorter machine downtime.

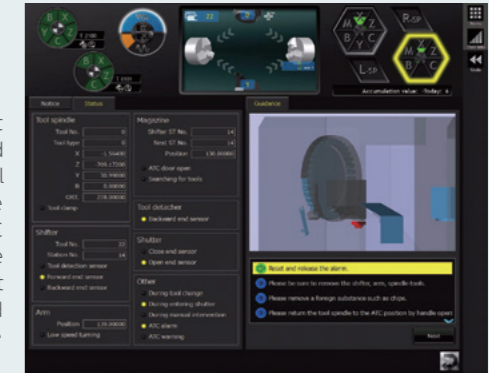

L-spindle

- Standard**
- Bar capacity **$\phi 65\text{mm}$**
- L-spindle motor **15/11kW**
4,500min⁻¹
- Option**
- Bar capacity **$\phi 80\text{mm}$**
- L-spindle motor **18.5/15kW**
3,500min⁻¹

* Specification of $\phi 51\text{mm}$ bar capacity is not available on R-spindle when $\phi 80\text{mm}$ bar capacity is selected on L-spindle.

R-spindle

- Standard**
- Bar capacity **$\phi 51\text{mm}$**
- R-spindle motor **11/7.5kW**
6,000min⁻¹
- Option**
- Bar capacity **$\phi 65\text{mm}$**
- R-spindle motor **15/11kW**
4,500min⁻¹

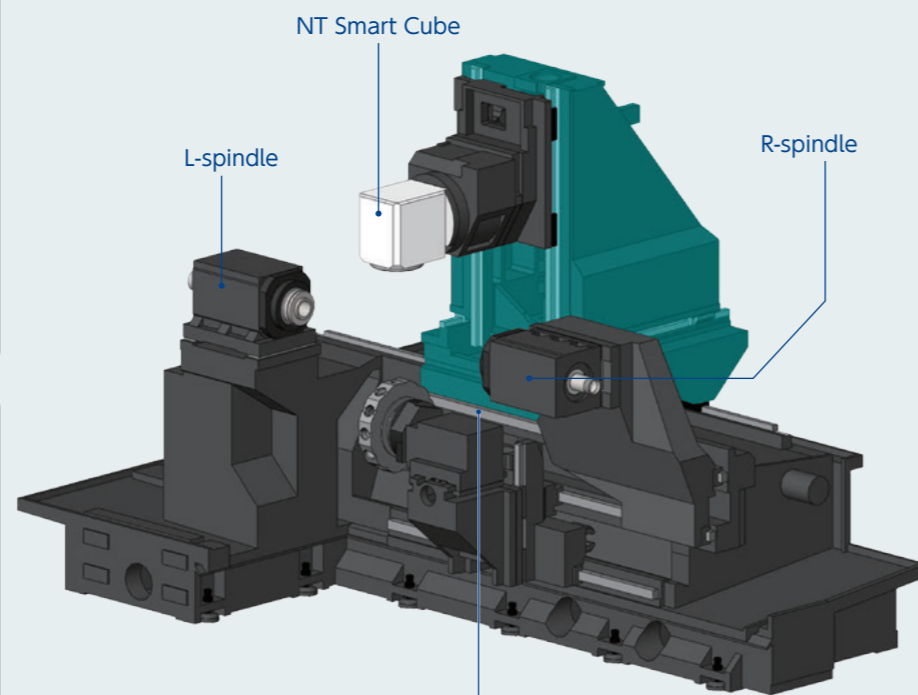

Stable and rigid structure with less vibration

High accuracy milling

Thanks to its long Y-axis travel and 50mm X-axis travel below the spindle center, various machining operations can be performed without rotating the C-axis. Among them, square milling in the X-Y plane or deep hole drilling in the X-axis direction ensuring faster cycle time and higher precision.

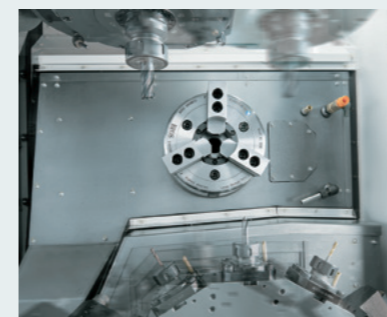

R-lower turret

- Y-axis slide travel **±35mm**
- 5.5/3.7kW**
- Milling motor **6,000min⁻¹**
8,000min⁻¹ (op.)

ATC 80 (op.40,120)



NT SmartX

Parts catcher type G		$\phi 65$	$\phi 80$
Workpiece size	Diameter (mm)	$\phi 12\sim 65$	$\phi 31\sim 80$
	Length (mm)	15~150	
	Weight (kg)	3.0	
Ejecting method		Belt conveyor & Chute	



Various Options to Meet our Customer's Needs. Total Provider for Peripheral Equipment.

Whether it is machine setup, cutting chip management, higher efficiency, or improved productivity, Nakamura-Tome offers top-class peripheral equipment, which boosts the performance of our Multitasking Machines. As a total solution provider using our vast experience, Nakamura-Tome offers complete solutions, including Multitasking Machines complemented with a great variety of peripheral equipment.



And many others. For items not listed, please feel free to contact your Nakamura-Tome representative.

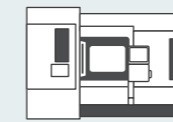

Initiatives in our products

Addition of eco-mode function to NT SmartX software
Improvement of power control system

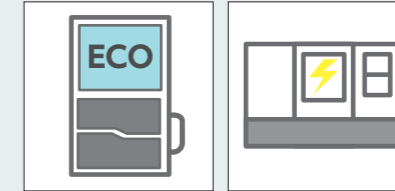

Cut down power consumption by approx. **68%**

* When ECO mode is enabled

Inverter-Driven Hydraulic Power Unit

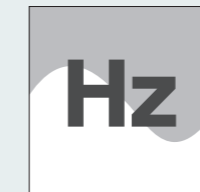

Cut down power consumption by approx. **45%**

* Compared with Super NTJX on standby mode

Reduction of oil consumption by changing from oil to grease lubricating

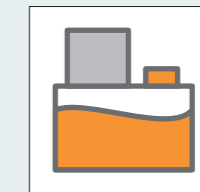

Cut down lubricating oil consumption by approx. **98%**

* Compared with Super NTJX



Parts catcher type A



Tool setter



Coolant pump



Chip conveyor

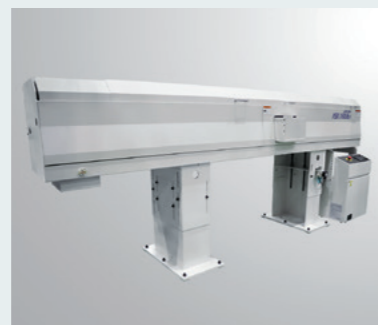

Bar feeder



Han-Bei (In-process measuring system)

Switching the power source is expected to reduce annual CO2 emissions by approximately 6,563 tons. (* 1)

Cedar trees 
Approx. **468,000 pcs** ^{*2}

CO₂ reduction 

(* 1) Actual values from April 2019 to March 2020
(* 2) Each cedar tree absorbs 14 kg of CO2 per year. (Source: Forestry Agency)

Nakamura-Tome is committed to the environment as an eco-friendly manufacturer.



NT SmartX

Full Operator Support from Ease of Use to Reliability

Main features of NT SmartX

Standard

- NT WORK NAVIGATOR
- Airbag (Overload detection)
- NT NURSE
- Status Display Function
- Setup Display
- Trouble Guidance
- Productivity Function
- Warm up Function
- Smart Support
- Drop Converter
- Cut in check
- Program Optimizer
- NT Machine Simulation
- NT Collision Guard
- NT Thermo Navigator AI
- Digital Chuck Interlock
- NT Manual Guide i
- One touch MDI
- 3D Smart Pro AI

- 19 inch color LCD touch panel
- QWERTY keyboard
- PC memory 8 GB
- Original Menu screen
- Voice Guidance
- Multi-Touch Screen
- Touch pad



Powered by AI as standard equipment

- NT Thermo Navigator AI
- 3D Smart Pro AI



Cut in check

NT Smart Sign

Nakamura-Tome IoT software

※Please refer to the NT Smart Sign exclusive catalog for details.

Monitoring



Real-Time Monitoring of machine running conditions, in addition to visualizing alarm history and past events.

Data Input / Output

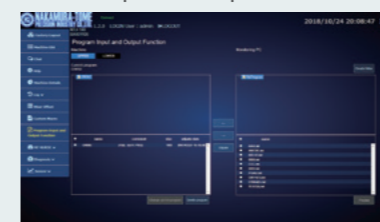

Input and output programs, tool data and other machine data from the monitoring PC.

Diagnosis

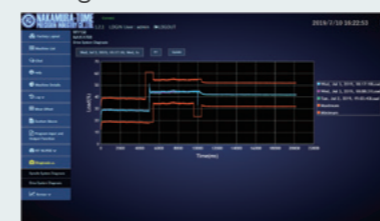

Diagnose problems with the machine servo drives and spindle drives, using a dedicated program.

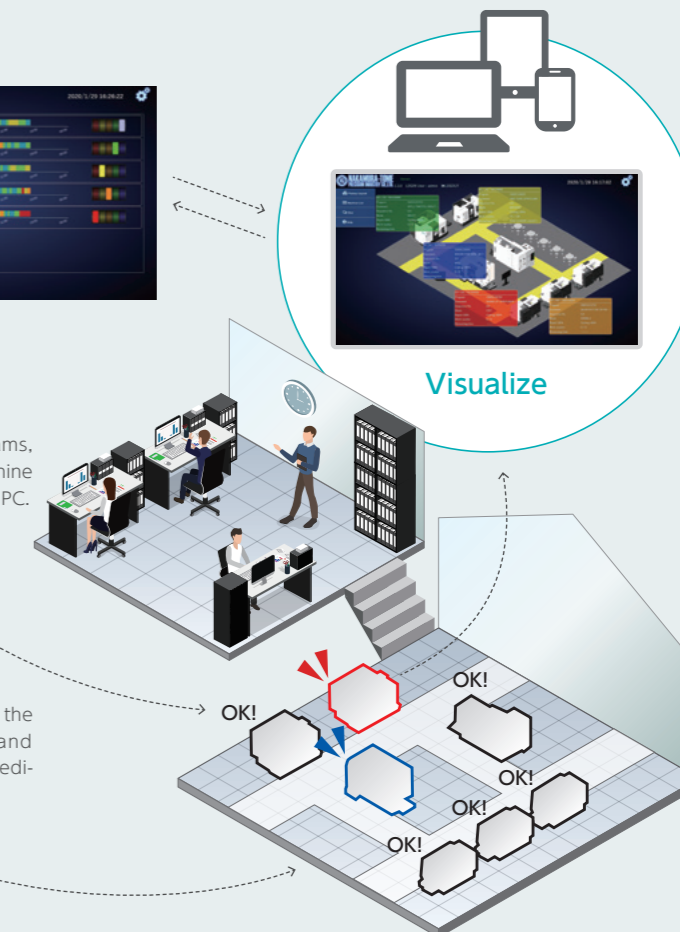

NT Thermo Navigator AI

Thermal Growth Compensation using AI.

Compensation model built using AI machine learning.

Powered by AI

Time and measured dimension data are input into a dedicated AI Learning software, to build an optimized thermal growth compensation model.



High Precision Thermal Growth Compensation

The compensation value is calculated from acquired data. The more data is input, the more accurate is the compensation value.

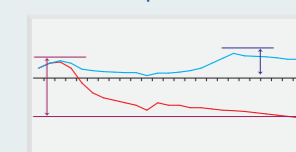

— Pre-correction thermal displacement data
— Thermal displacement data after correction

- ① Time
- ② Measured Dimensions
- ③ Retrieval of Wear Offset Data

Acquired Data analyzed with NT Thermo Navigator AI



Feedback



Standard for NT Smart X



Digital Chuck Interlock

Set the Chuck Open and Close detection position easily. The chuck open / close position is set up on the NT SmartX screen. Setup time and machining cycle time are reduced.

One Touch MDI

This function is to register frequently used program blocks or cycles, such as zero return or tool change, and call them again with one touch.

Reduce programming and setup time while eliminating input errors.

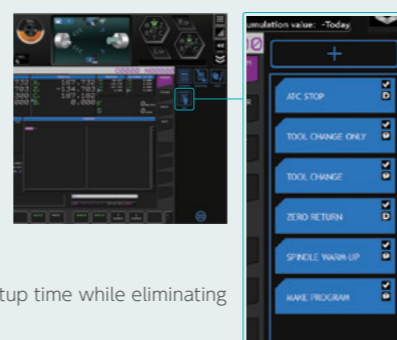

3D Smart Pro AI AI analysis NC programming support function

From the 3D CAD drawing, AI automatically analyzes "model geometry", "machining path", "machining tools", "machining conditions", and "machining process sequence", to create NC programs for all processes from raw material to finished product.

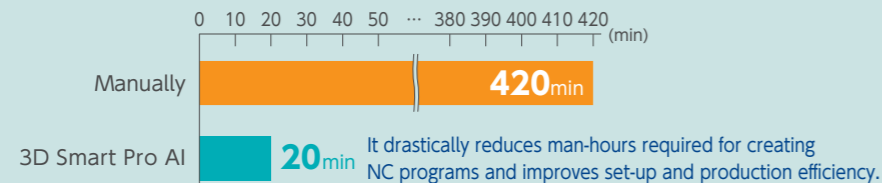
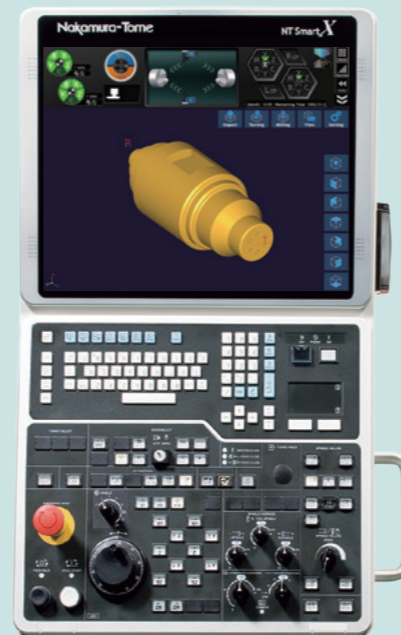
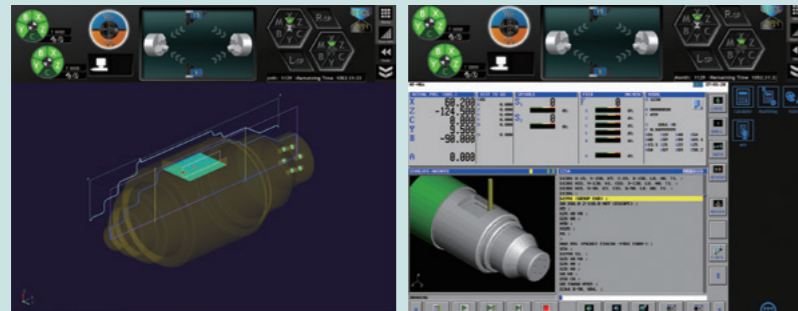

3 useful features available with 3D Smart Pro AI

1. Transfer setting

Once the transfer position is set, the machining area and transfer program are created.



2. Optimization of machining processes

In addition to defining the required machining processes, AI proposes a suitable machining process sequence.



3. Tolerance setting

Once the tolerance value is input, the target value for machining can be set.



NT WORK NAVIGATOR



No fixtures required

Machining parts with non-round shapes, such as forgings or castings require that the raw part coordinates be recognized by the CNC control.

It works just by touching the part with a simple inexpensive probe (mostly a round bar mounted on a tool holder) and using the torque control feature of the servo-motor, which is to record required coordinates in the CNC.

The NT WORK NAVIGATOR is eliminating the need for positioning fixtures and special clamping devices.

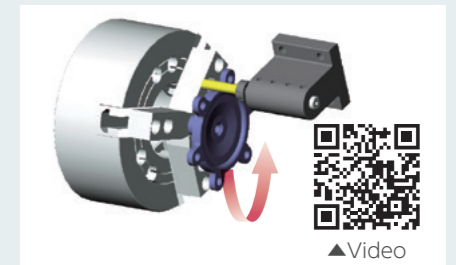

Double safety features for maximum protection

NT Machine Simulation / NT Collision Guard + Airbag (Overload detection)

The machine comes protected with dual safety features: "NT Machine Simulation / NT Collision Guard" to prevent a collision beforehand, and the "Airbag Function" minimizes damage to the machine in case of collision.

NT Machine Simulation

Machine collisions are avoidable with Preventive safety technology!

By checking in advance for interference between chucks and tools, or between tools and covers, etc, in addition to checking the machining processes, the risk of a machine collision is drastically reduced, and the machining processes can be optimized.



Simulation is performed while checking the remaining movement amount and modal information.

It is possible to override the settings for rapid and cutting feed individually. Additionally, simulation by process or by single block is possible.

By process
Single feed

Image shown here is of a 2-turret machine

NT Collision Guard

Available in automatic or manual mode. Using the built-in 3D models on the machine, chucks, tools, holders, and parts, machine collisions can be monitored and prevented in real-time during automatic, manual, or jog movements. Even turret indexing is monitored to prevent collisions, drastically reducing collision risks, especially during machine setup.



Image shown here is of a Tool spindle machine

Airbag (Overload detection)

Compared to other machines, Nakamura-Tome machines will not break after the slightest collision. The "Airbag Function" minimizes the damage that may occur during a collision.

If a machine collision occurs, there is good reason to be confident: Airbag !

When the machine collides, there is no reason to panic.

The Airbag (Overload detection) of the machine tool significantly reduces the impact of a collision and protects the machine.



Without Airbag

Machines will not stop immediately. The slide continues to move even after a collision.



▲Video



With Airbag

Retraction within 0.001 sec

Crash? Within one millisecond after a collision, the servo motor direction is reversed, and the machine stops in EMG mode.



* This feature does not mean zero impact

Chatter Cancellor

Reduce the chatter and vibration by changing the spindle speed up/down continuously during cutting. This function can be turned ON/OFF simply by M code.

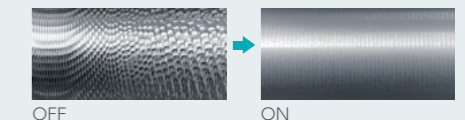

* It does not warrant that the function works without chatter and vibration.
* Chatter and vibration reduction depend on the setup and the cutting condition.

Oscillation cutting (op.)

By oscillating the tool for a certain period, the chips are cut into small pieces. It can be activated easily by using a simple Fanuc G-code and resolve workpiece damage issues caused by chips twined around the part.



Material : Aluminum
Cutting speed : 200mm/min

Cutting feed : 0.1mm/rev
Cutting depth : 1.0mm

L-spindle motor

Bar capacity $\phi 65\text{mm}$ 15/11kW

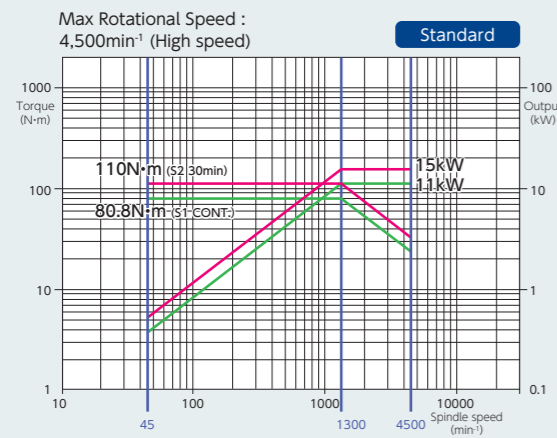

Bar capacity $\phi 80\text{mm}$ 18.5/15kW

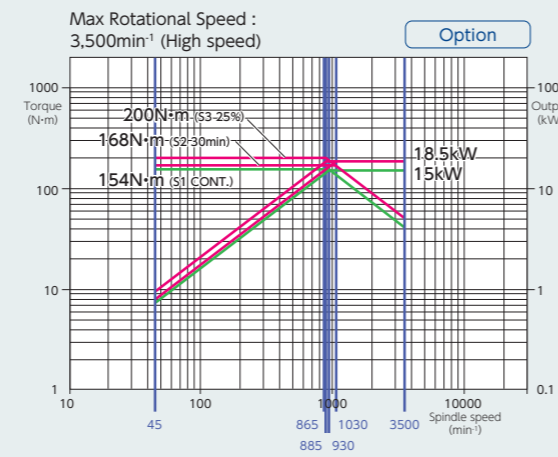

R-spindle motor

Bar capacity $\phi 51\text{mm}$ 15/11kW

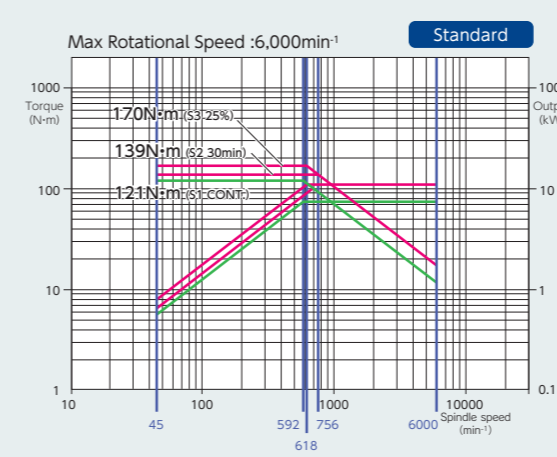

Bar capacity $\phi 65\text{mm}$ 15/11kW

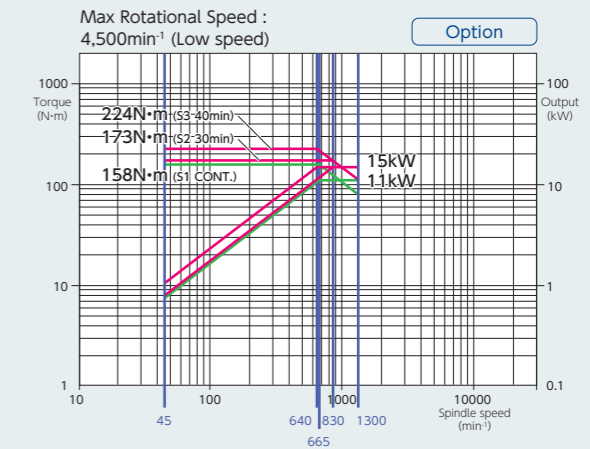
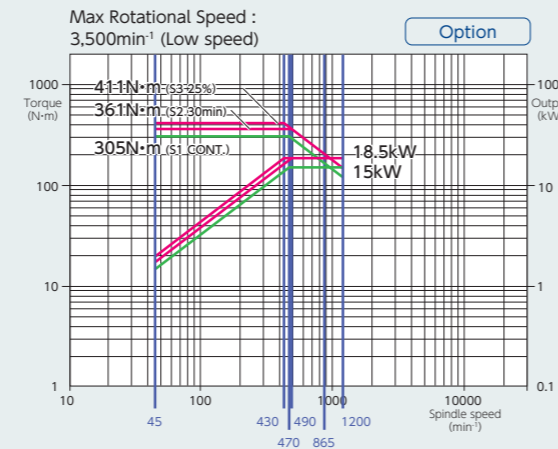
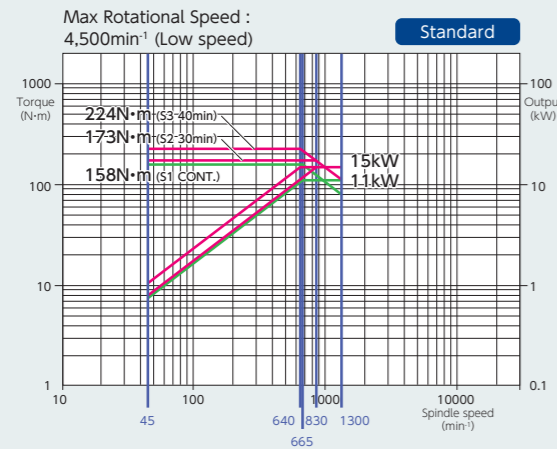
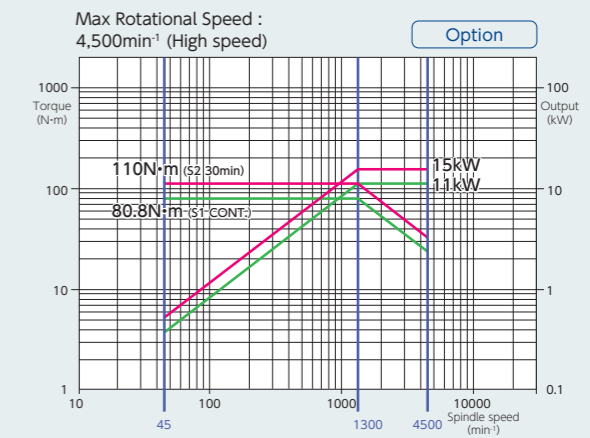

Tool spindle motor

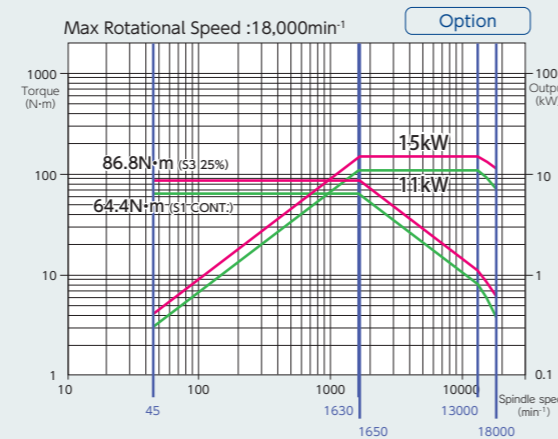
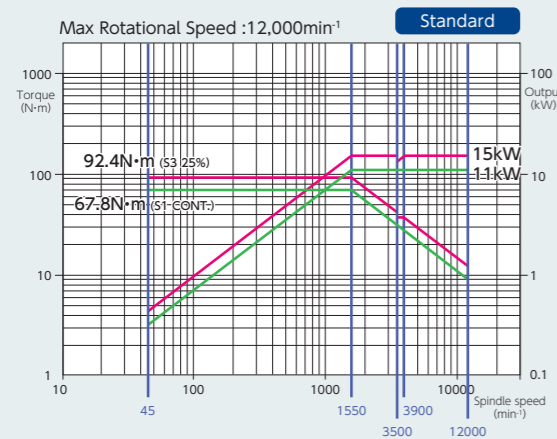

Milling motor

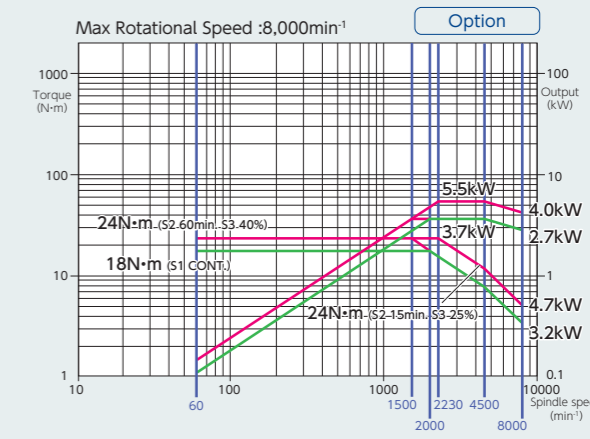
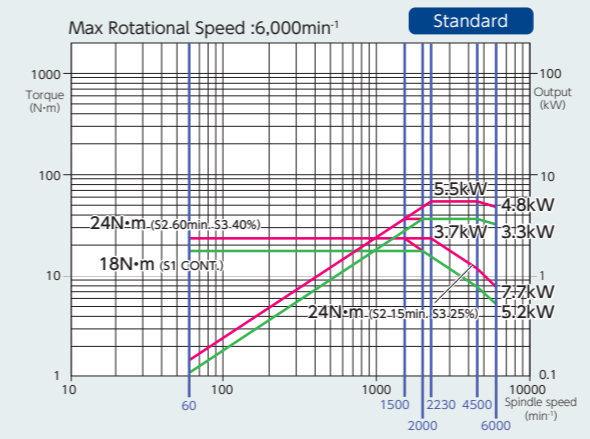

Tooling System Sandvik Coromant Capto C6



* For details, refer to the Sandvik Coromant Tooling Catalog.

Machine Dimensions

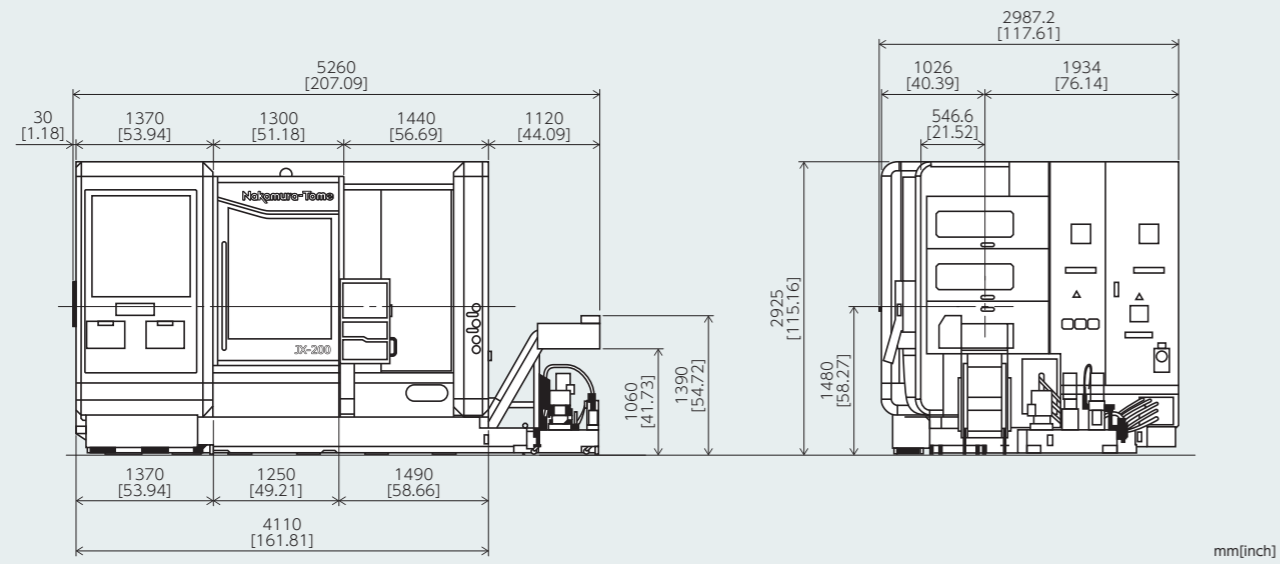

Travel Range

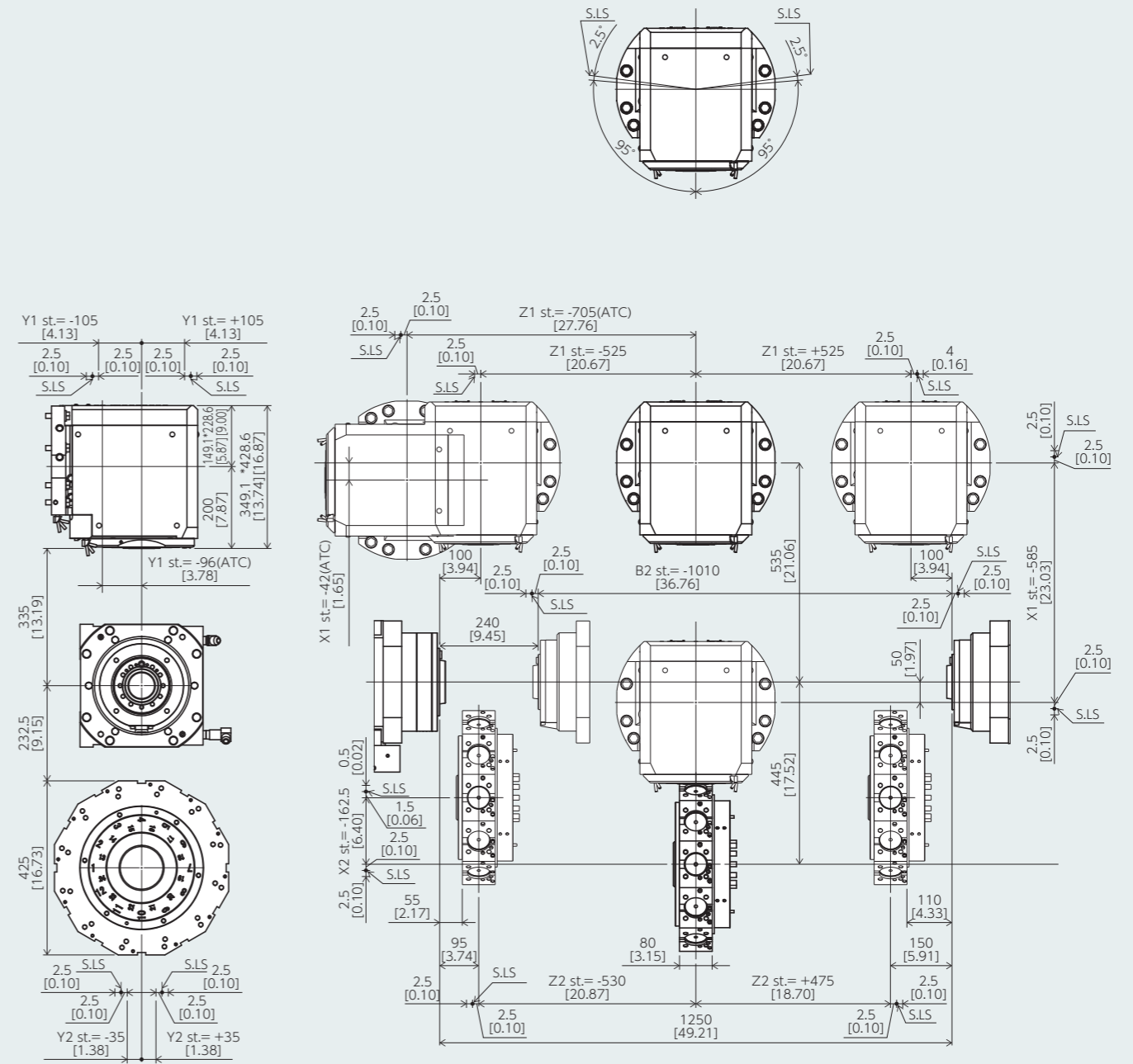

Maximum Tool Diameter

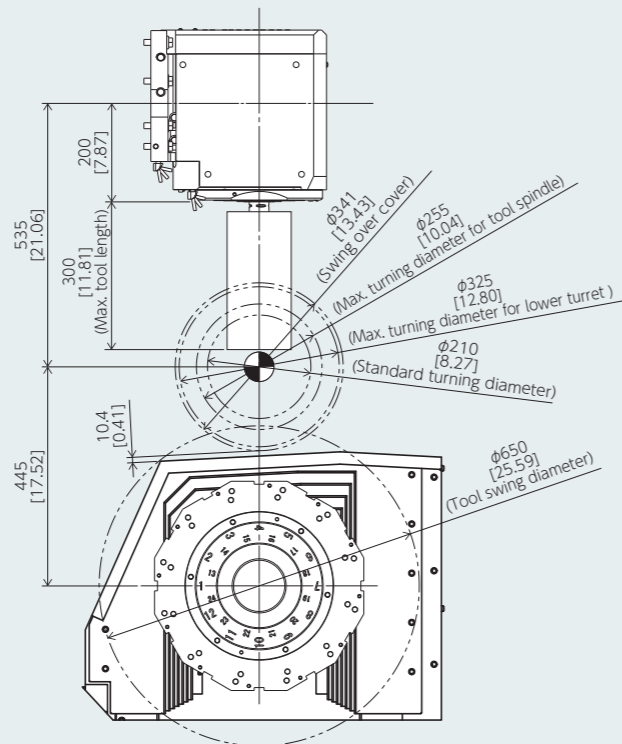

*For tool spindle speed 18,000min⁻¹

Capacity	φ51	φ65	φ80*
Max. turning diameter (Tool spindle / Lower turret)	325mm / 255mm		
Distance between spindles	max.1,250mm / min.240mm		
Max. turning length	1,058mm		
Bar capacity	φ51mm	φ65mm	φ80mm
Chuck size	6" / 8"		

■ Axis travel

X1-Axis slide travel	585mm
X2-Axis slide travel	162.5mm
Z1-Axis slide travel	1,050mm (at ATC+180mm)
Z2-Axis slide travel	1,005mm
Y1-Axis slide travel	±105mm
Y2-Axis slide travel	±35mm
B2-Axis slide travel	1,010mm

■ Rapid feed

X1-Axis rapid feed rate	30m/min
X2-Axis rapid feed rate	16m/min
Z1-Axis rapid feed rate	40m/min
Z2-Axis rapid feed rate	40m/min
Y1-Axis rapid feed rate	16m/min
Y2-Axis rapid feed rate	6m/min
B2-Axis rapid feed rate	40m/min

■ L-spindle

		φ65	φ80(op.)*
Spindle speed	-	4,500min ⁻¹	3,500min ⁻¹
Spindle speed range	-	Stepless	Stepless
Spindle nose	-	A2-6	A2-8
Hole through spindle	-	80mm	90mm
I.D. of front bearing	-	120mm	130mm
Hole through draw tube	-	66mm	81mm

■ R-spindle

	φ51	φ65(op.)	
Spindle speed	6,000min ⁻¹	4,500min ⁻¹	-
Spindle speed range	Stepless	Stepless	-
Spindle nose	A2-5	A2-6	-
Hole through spindle	63mm	80mm	-
I.D. of front bearing	100mm	120mm	-
Hole through draw tube	52mm	66mm	-

* Specification of φ51mm bar capacity is not available on R-spindle when φ80mm bar capacity is selected on L-spindle.

■ Safety quality specifications

Various interlocks, such safety fences, auto extinguisher devices, and other safety related equipment may be required. These have to be selected during the configuration of the machine.

① Safety devices include electromagnetic door lock, chuck interlock, hydraulic pressure switch, air pressure switch, short circuit breaker and quill interlock.
(Door interlock and chuck interlock are standard equipment.)

② In the case of automation, various safety fences may be required, such as work stocker safety fences, robot safety fences, etc.

During the configuration of machine specifications, please discuss these requirements with the Nakamura-Tome machine sales representative.

■ ATC Tool spindle

Tool spindle speed	12,000min ⁻¹ / 18,000min ⁻¹ (op.)
Swiveling range	190° (±95°)
Tool coupling type	CAPTO C6 / HSK-T63(op.)
Number of tools	80, (40, 120 op.)
Max. tool diameter / Without adjacent tool	90mm / 130mm
Max. tool length	300mm

■ Lower turret

Type of turret head	Dodecagonal drum turret
Number of tool stations	12 (Max.24)
Number of Indexing positions	24
Tool size (square shank)	□25mm
Tool size (round shank)	φ32mm

■ Milling

Rotary system	Individual rotation
Milling spindle speed	6,000min ⁻¹ / 8,000min ⁻¹ (op.)
Spindle speed range	Stepless
Number of milling stations	12
Tool size	Straight holder φ1mm ~ φ16mm
	Cross holder φ1mm ~ φ16mm

■ Drive motor

	φ51	φ65	φ80*
L-spindle	-	15/11kW	18.5/15kW(op.)
R-spindle	11/7.5kW	15/11kW(op.)	-
Tool Spindle	15/11kW		
Milling (Lower turret)	5.5/3.7kW		

■ General

Height	2,925mm	
Floor space (L x W)	5,250mm × 2,987.2mm	
Machine weight (incl. control)	ATC 80	23,000kg
	ATC 40(op.)	22,500kg
	ATC 120(op.)	24,000kg

■ Power requirements

Power supply	59.5kVA(63.5kVA) (L-spindle 15/11kW, R-spindle 11/7.5kW)
	62.5kVA(66.5kVA) (L-spindle 15/11kW, R-spindle 15/11kW)
	66.1kVA(70.1kVA) (L-spindle 18.5/15kW, R-spindle 15/11kW)

■ Precautions on the use of cutting fluids and lubricating oils

Some types of cutting fluids (coolant) are harmful to machine components, causing damages such as peeling of paint, cracking of resin, expansion of rubber, corrosion, and rust build-up on aluminum and copper.

To avoid causing damage to the machine, never use synthetic coolants, or any coolants containing chlorine. In addition, never use coolants and lubricating oils which contain organic solvents such as butane, pentane, hexane, and octane.

■ Items

Control Type	FANUC 31i-B5 Plus(2-PATH)
--------------	---------------------------

■ Controlled axes

Controlled axes	10 axes	
Simultaneously Controlled axes	Upper	5 axes(X1, Z1, C1(C2), Y1, B1 axis)
	Lower	5 axes(X2, Z2, C2(C1), Y2, B2 axis)

■ Input command

Least input increment	X,Z,Y,B2:0.001mm/0.0001inch (diameter for X-axis), C,B1:0.001°
Least command increment	X:0.0005mm / Z,Y,B2:0.001mm / C,B1:0.001°
Max. programmable dimension	±999999.999mm / ±39370.0787in , ±999999.999°
Absolute/ Incremental programming	X, Z, Y, C, B(absolute only for B) / U, W, V, H
Decimal input	Standard
Inch / Metric conversion	G20 / G21
Programmable data input	G10

■ Feed function

Cutting feed	feed/min	
	X, Z:	1 ~ 8000mm/min, 0.01 ~ 315inch/min (1 ~ 4800mm/min, 0.01 ~ 188inch/min)
	Y1:	1 ~ 8000mm/min, 0.01 ~ 315inch/min (1 ~ 4800mm/min, 0.01 ~ 188inch/min)
	Y2:	1 ~ 6000mm/min, 0.01 ~ 236inch/min (1 ~ 4800mm/min, 0.01 ~ 188inch/min)
	C:	1 ~ 4800°/min
	B1:	1 ~ 8000° /min (1 ~ 4800° /min)
	B2:	1 ~ 8000mm/min, 0.01 ~ 315inch/min (1 ~ 4800mm/min, 0.01 ~ 188inch/min)
	feed / rev	0.0001 ~ 8000.0000mm/rev (0.0001 ~ 4800.0000mm/rev) 0.000001 ~ 50.00000inch/rev
		The maximum cutting feed rate is the value in AI contour control mode. In normal operation, it is enabled with G316 command. The values in parentheses are normal values.

Dwell	G04
Feed per minute / Feed per revolution	G98 / G99
Thread cutting	G32F designation
Thread cutting retract	Standard
Continuous thread cutting	Standard
Handle feed	Manual pulse generator 0.001/0.01/0.1mm [°] (per pulse)
Automatic acceleration / deceleration	Standard
Linear accel./ decel. after cutting feed interpolation	Standard
Rapid feed override	Low/25/50/100% (can be set from 0~100 in 10% intervals on NT Setting screen)
Cutting feedrate override	0 ~ 150%, 10% (each 10%)
AI contouring control I	G5.1
L- Spindle override	50%~ 120% Set every 10%
R-Spindle override	50%~ 120% Set every 10%
Tool Spindle override	50%~ 120% Set every 10%

■ Program memory

Part program storage length / Number of registrable programs	4Mbyte Total 10240m	4000
	8Mbyte Total 20480m(op.)	
Parts program editing	delete, insert, change	
Program number search	Standard	
Sequence number search	Standard	
Address search	Standard	
Program storage memory	Battery backup	
Background editing	Standard	
DNC operation through memory card	Standard (Not including memory card)	
Extended part program editing	Standard	

■ Operation and display

HMI (Human Machine Interface)	NT SmartX
Operation panel : Display	19-inch color SXGA LCD touch panel
Operation panel : Keyboard	QWERTY keyboard

■ Programming assist functions

Circular interpolation R programming	Standard
Direct drawing dimension programming or Chamfering/ Corner R	Standard (Direct drawing dimension programming is standard)
Canned cycles	G90, G92, G94
Multiple repetitive canned cycles	G70 ~ G76
Multiple repetitive canned cycles II	G71, G72
Canned cycles for drilling	G80 ~ G89
Sub program	Standard
Custom macro	Standard (common variables #100 - #149, #500 - #549)
Additional custom macro variables	Standard (After addition, #100 - #199, #500 - #999, #98000 - #98499)
Luck-bei II / NT Manual Guide i	Standard
Abnormal load detection function	Standard
NT Work Navigator	Standard(not including contact bar)
NT NURSE	Standard

■ Machine support functions

Rigid tapping	Standard
Spindle synchronized control	Standard
C axis synchronized control	Standard(G496 C1. rapid feed positioning)
Spindle orientation	Standard
Tool spindle orientation	Standard : 4 positions (4×90°)(M785/M786/M787/M788)
	Maximum : 12 positions(12×30°)(G419)

■ ECO functions

Servo motor power off	Standard(Switch on Power Saving Mode in NT Setting screen)
Control of motor output during acceleration and deceleration	Standard(Switch on Power Saving Mode in NT Setting screen)
G code for servo motor energy-saving during acceleration and deceleration	G356/G357
Automatic light off	Standard(Switch on Power Saving Mode in NT Setting screen)
Automatic monitor off	Standard(Switch on Power Saving Mode in NT Setting screen)



NAKAMURA-TOME PRECISION INDUSTRY CO., LTD.

<https://www.nakamura-tome.co.jp>

Netsuno 15, Hakusan city, Ishikawa, 920-2195 Japan
Phone : +81 76 273 8100 Fax : +81 76 273 4312
E-mail : nt-jpn@nakamura-tome.co.jp

- * This catalog was published in September 2022. Specifications, illustrations and data given herein are subject to change without notice.
- * The products in this catalog are controlled by Japan's "Foreign Exchange and Foreign Trade Law". The export of the products is subject to an export license to be issued by the Japanese government.

