

SPEEDIO

U500Xd1

Universal Compact Machining Center



**Machine Tools Sales Department,
Machinery Business Division,
Brother Industries, Ltd.**

SPEEDIO U series Introduction of **U500Xd1**

1. Description of ***SPEEDIO***
2. Outline and Advantages
3. Performance and Features
4. Machining demonstration

Cutting Out the Waste

Times are changing. Are you ready?
You need a machine that's fast and compact.
With the ability to make any cut.
In this world, only the strong survive.
Make it better with SPEEDIO.

SPEEDIO



SPEEDIO

SPEEDIO is a brand of No. 30 machine for customers who demand high productivity, which has high machining ability while having compactness and speed not found in No. 40, and is eco-friendly





SPEEDIO for the Environment Looking to Achieve Carbon Neutrality

While retaining the #30 spindle, and based on Brother's original technology, the *SPEEDIO* strives for industry-leading environmental performance, in addition to overwhelming high productivity, machining capabilities, and usability.

When machining is performed by replacing a general #40 machining center with the *SPEEDIO*

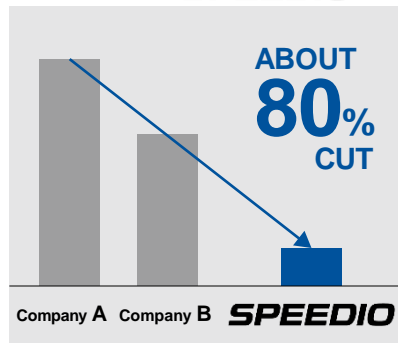

Power-Saving Functions

Power Regeneration system

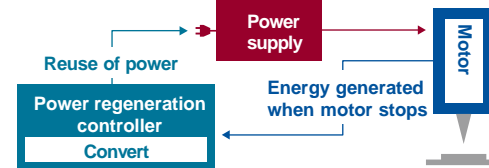

Power consumption application



- LED work light
- Coolant automatically turns OFF
- Standby mode
- Machine light automatically turns OFF
- Display automatically turns OFF
- High efficiency pump, etc.

U

SPEEDIO

U500Xd1

Universal
Compact Machining Center



S

Compact Machining Center

S300Xd1 S500Xd1 S700Xd1



R

Compact Machining Center
Equipped with Pallet Changer

R450Xd1 R650Xd1



W

Wide Stroke
Compact Machining Center

W1000Xd1



M

Compact Multitask Machine

M200X3 M300X3



F

High Rigidity
Compact Machining Center

F600X1



Special Options
T-200A/ BV7-870
T-200Ad



2. U500Xd1 Outline and Advantages

Market environment changes

In response to a shift to EVs in the automobile industry, materials for parts has changed from iron to aluminum die cast and integration of functions has progressed.

- **Parts have become larger.**
- **Medium- to large-size aluminum workpieces that require multi-face machining have increased.**

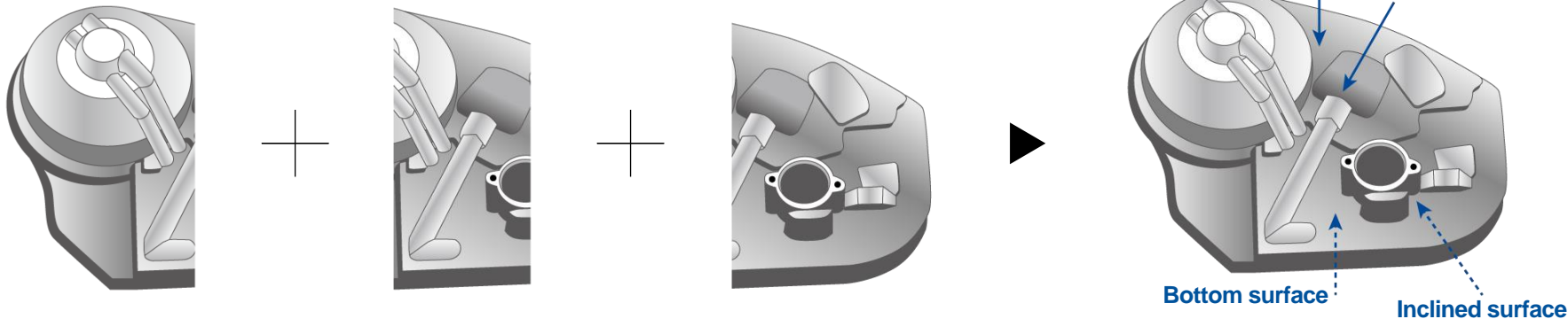

Presently, development of EV parts is in its early days. Therefore, designs change frequently, and the life span of products becomes shorter accordingly.

→ To respond to “frequent process changes” and “fluctuation in production volume,” and to achieve “stable accuracy of multi-face machining”

Needs for process integration have increased.

Selection currently available

#30 machines offer sufficient machining capability, however,

- To perform multi-face machining, **fixture area is insufficient.**
- To mount a large tilting rotary table, **max. loading weight is insufficient.**

#30 machine with built-in 5 axes

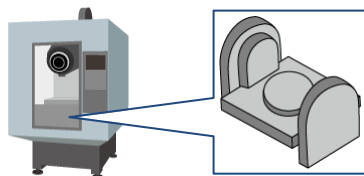

Competitors' #30 machine
with built-in 5 axes
Fixture rea:
Approx. $\Phi 350$ mm

**Insufficient
jig area**

#30 machine + Tilting rotary table

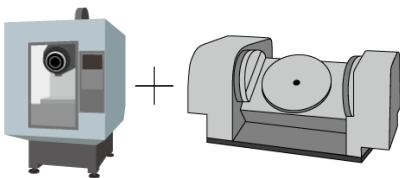

Tilting rotary table
Fixture area **$\Phi 500$ mm**
Weight **approx. 1200 kg**

**Insufficient
max. loading
weight**

**Users are obliged to select
expensive #40 machines.**

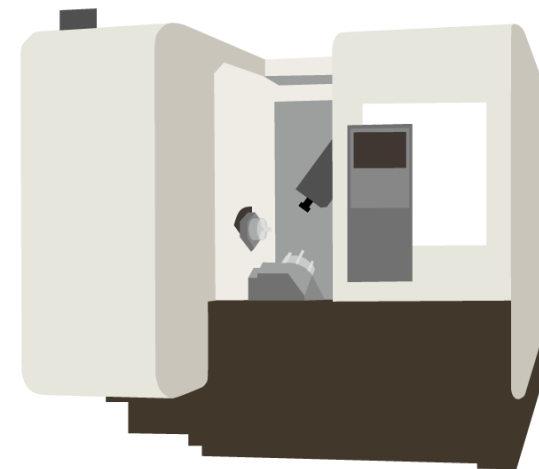

New structure that enables process integration

***SPEEDIO* U500Xd1** Universal Compact Machining Center

SPEEDIO Built-in large tilting rotary table

28-tool high-speed turret magazine



Universal Compact Machining Center that encourages process integration through multi-face machining

Compact Machining Center
SPEEDIO

U500Xd1



Travels X / Y / Z	500 mm / 400 mm / 300 mm
Travels A (tilt axis) / C (rotary axis)	150° (-30° to +120°) / 360°
Max. loading capacity	100 kg
Max. spindle speed	10,000 min ⁻¹ / 16,000 min ⁻¹ (Optional) (High-torque spec. and 27,000 min ⁻¹ spec. not available)
Tool storage capacity (pcs.)	14 / 21 (Optional) / 28 (optional)
Spindle options	BT dual contact spindle Coolant Through Spindle (CTS) 3.0 MPa / 7.0 MPa *

* Only piping is provided when 7 MPa is selected.

Multi-face machining of mainly die cast parts, using large tilting rotary table

Automobile

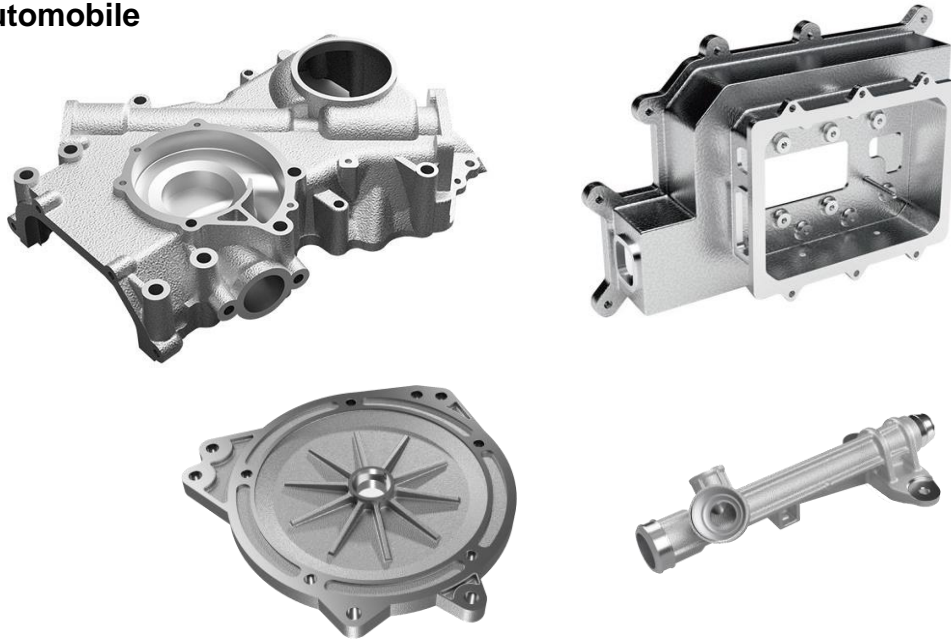

Aircraft

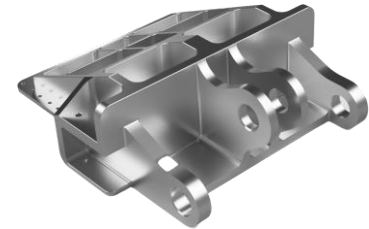

Medical



Ample fixture area

As parts are becoming larger, the fixture area of #30 multi-face machining machines is not sufficient.



**The U500Xd1 provides ample fixture area of $\varnothing 500$ mm.
Large workpieces can be mounted.**

Normal #30 multi-face machining center
Fixture area: Approx. $\varnothing 350$ mm

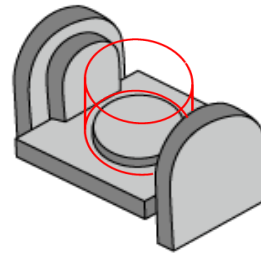

U500Xd1
Fixture area: $\varnothing 500$ x 270

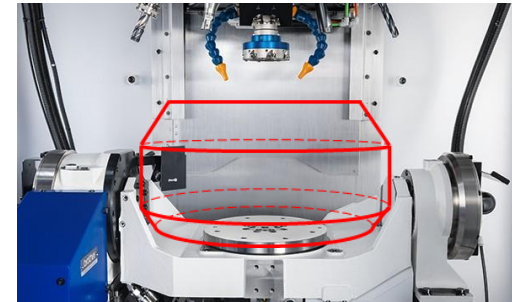

28-tool magazine available

As parts are becoming complex, the number of tools set is often insufficient.



A space-saving 28-tool magazine is available.

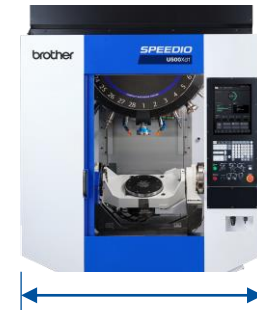

Same machine width as when a 14- or 21-tool magazine is mounted

Roller gear cam used for A and C axes

Achieves backlash-free operation and high rigidity.
As there is very little abrasion, adjustment is not necessary.

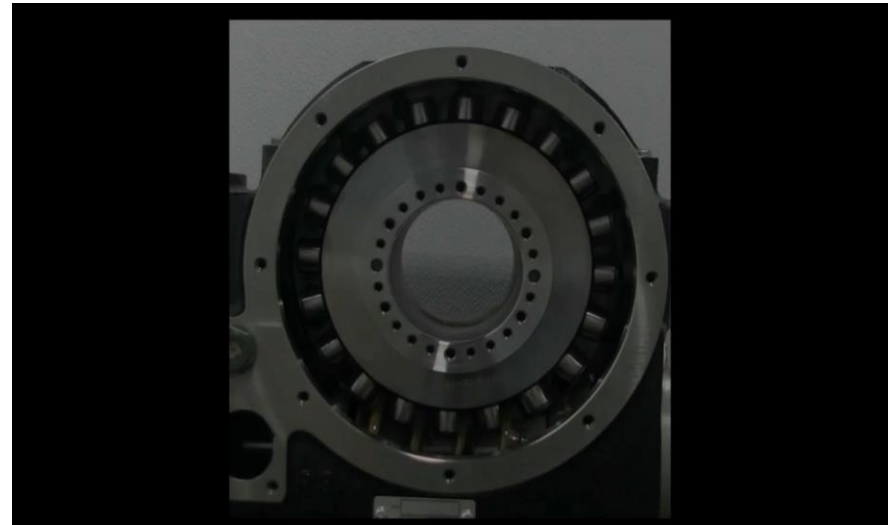
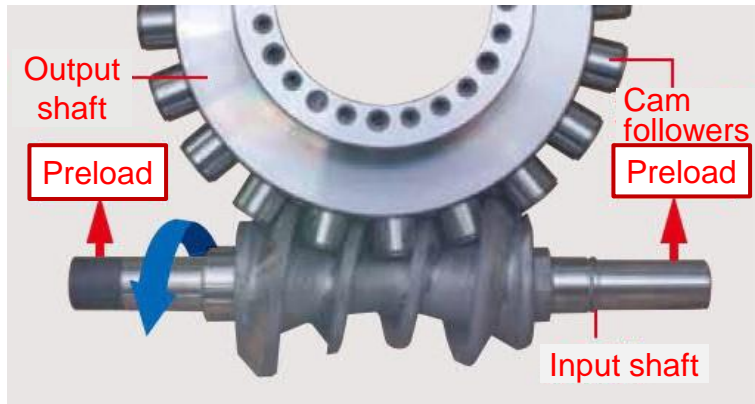

Process division and process integration (ex. inverter case machining)

Process division: 4 machines

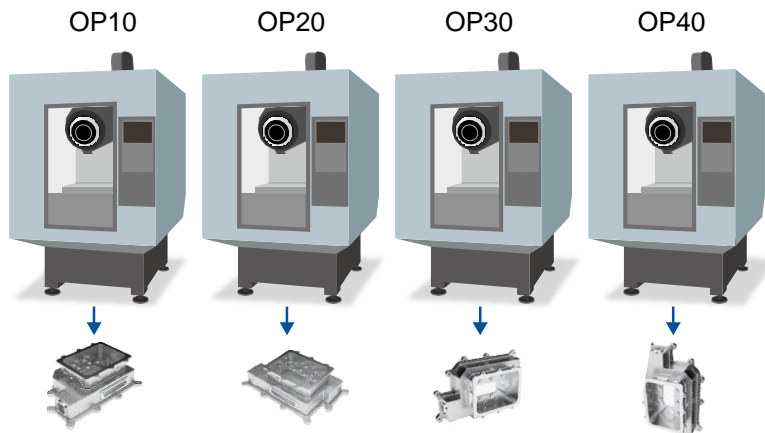

- Although cycle time is shorter, machining time balance adjustment is required.
- Required process design time is longer.

Process integration: 2 machines x 2 cells

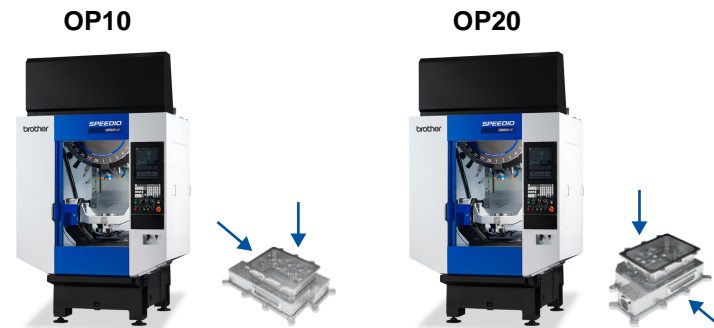

- Although cycle time is longer, machining time balance adjustment is easier.
- Process design time can be shortened.
- Can easily respond to short product life span.
- Can easily secure multi-face machining accuracy.

3. Performance and Features

3. Performance and Features



① Tool magazine

Available with 28-tool magazine option

(Selected from 14-, 21-, or 28-tool magazine)



② Spindle

Coolant Through Spindle withstand 7 MPa (optional)

③ Machining capability

Increase in max. tool weight 4 kg *1

④ Table

Table loading capacity 100 kg

⑤ Equipped with large tilting rotary table using roller gear cam

*1: Parameter setting needs to be changed.

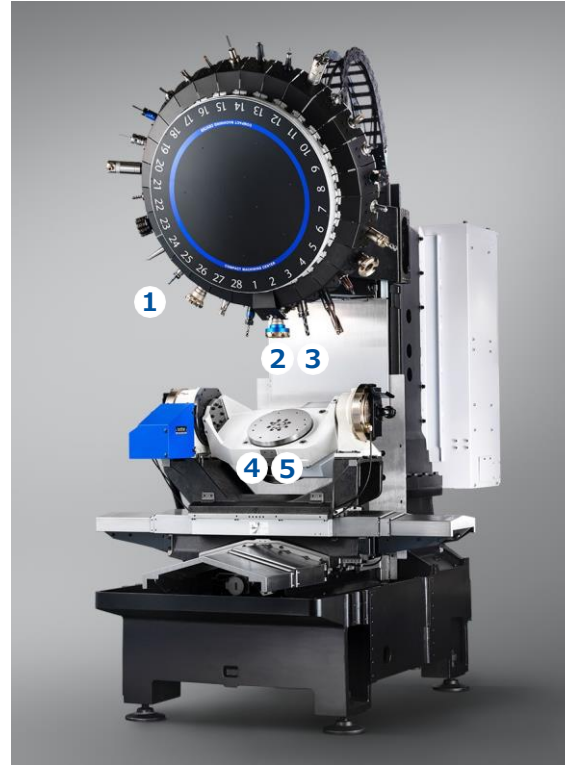

New controller CNC-D00





**Extensive
Machine Performance**

**Pursuit of
High Productivity**

**Advanced
New D00 Control**

**Untiring Improvement
of Reliability**



Extensive Machine Performance

Pursuit of
High Productivity

Advanced
New D00 Control

Untiring Improvement
of Reliability

Tilting rotary table is incorporated to secure ample fixture area

Travel area

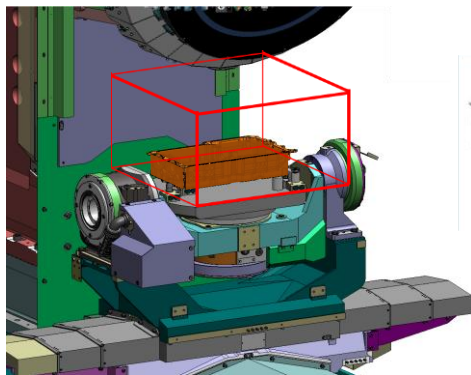

Workpiece size
400×230×90 mm



Travel area

Jig mounting area

A-axis at 0 deg.

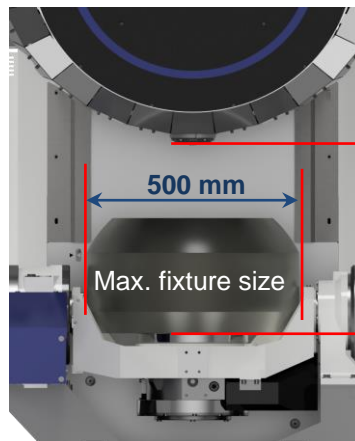

A-axis at 90 deg.

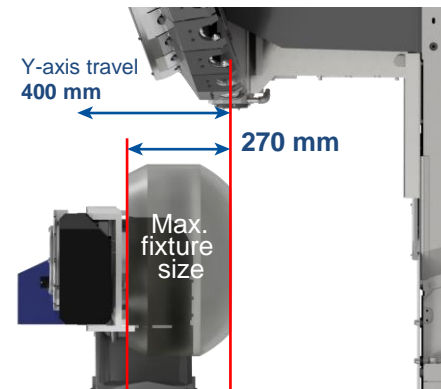

Fixture mounting area	ø500 mm × 270 mm
Travels	X 500 mm × Y 400 mm × Z 300 mm
Max. loading weight	100 kg

Using roller gear cam ensures high accuracy and long service life

The “cam” and “special cam follower” constantly make line contact from left and right to ensure backlash-free operation.

This enables highly accurate positioning, **leading to improvement of machining accuracy.**

The “cam” and “special cam follower” are rolling bearings.

There is little wear even after long periods of operation.

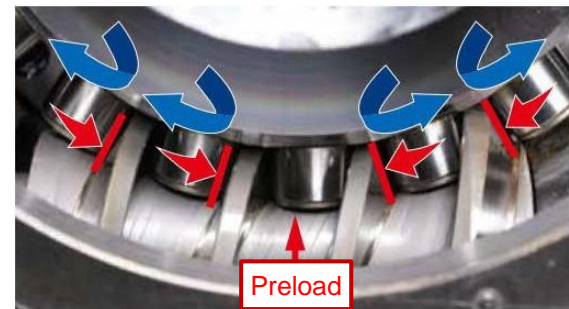

High inertia mode enables handling of heavy fixtures

In general, complex fixtures such as hydraulic clamping systems are heavy and have high inertia.

Since a high inertia mode is prepared, there is no need to spend design man-hours on fixture weight reduction (lower inertia).

	Allowable inertia (kg·m ²)	High inertia mode Allowable inertia (kg·m ²)
Around A-axis	1.5	←
Around C-axis	1.8	2.6

※High inertia mode requires setting of machine parameters, with a maximum C-axis speed of 60 min-1.

28-tool magazine has been available to enhance process integrated machining

In addition to the 14-tool magazine, 21- and 28-tool magazines are optionally available.

The 28-tool magazine satisfies the tool capacity required for process integration.

Max. tool length: 250 mm Max tool weight: 4 kg

14-tool magazine



21-tool magazine



28-tool magazine



* When the tool weight exceeds the standard spec. of 3 kg, there are some restrictions on ATC magazine loading capacity or speed adjustment is required.

Suitable spindle can be selected for machining details

Spindle speed: 10,000 min⁻¹ / 16,000 min⁻¹ (optional) Spindle taper: BT / BT dual contact (optional)

Coolant Through Spindle (CTS) 3.0 MPa / 7.0 MPa

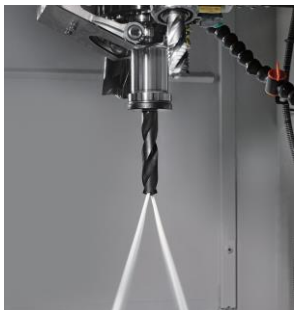

- Using high-pressure CTS piping (optional) or 3 MPa CTS improves machining efficiency.

Using side door improves visibility.

- Side door (OP) improves visibility even when machining with tilted A-axis.

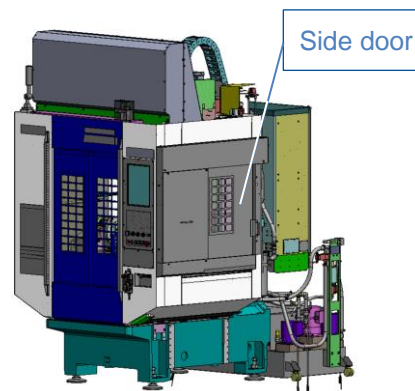

Using rotary joint for A/C axes makes fixture design easier

- As it includes piping between A/C axes, available by only connecting both sides.

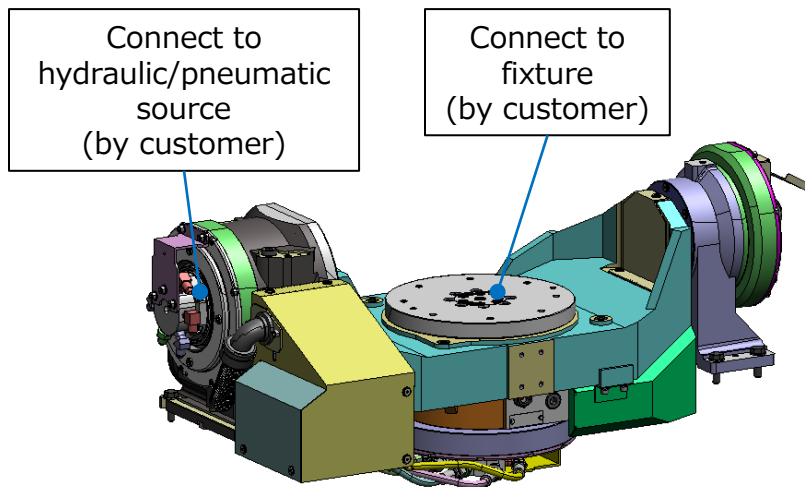

Piping between A/C axes already installed

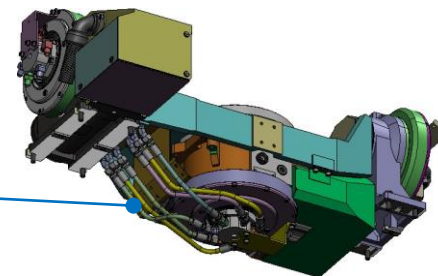

	Rotary joint (optional)
Hydraulic or pneumatic	6 ports
Withstand pressure	Hydraulic: 7 MPa Pneumatic :1 MPa
RJ(A) ↔ RJ(C)	Hydraulic hose



Extensive
Machine Performance

Pursuit of
High Productivity

Advanced
New D00 Control

Untiring Improvement
of Reliability

Roller gear cam used to ensure high productivity

Roller gear cam suitable for high-speed rotation is used for A and C axes to ensure high productivity.

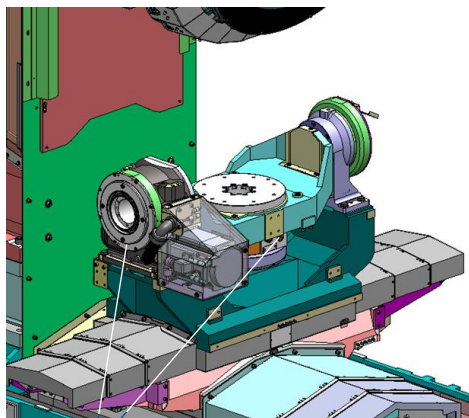

**Roller gear cam used
for A and C axes**

Indexing feed rate

	Indexing feed rate(min ⁻¹)	High inertia mode Indexing feed rate(min ⁻¹)
A-axis	50	←
C-axis	75	60

Positioning time

	90 deg.	180 deg.
A-axis	0.9 s	—
C-axis	1.2 s	1.4 s

*at standard inertia mode, including clamping time

Non-cutting time has been reduced to achieve high productivity

“Non-stop ATC” has been achieved by reducing wasted time, such as in tool change time, shifting from cutting to non-cutting motion, and positioning time.

	14 / 21 tools	28 tools
Tool To Tool	0.6 s	0.7 s
Chip To Chip	1.2 s	1.3 s

Wasted time at ATC has been further reduced by simultaneous operation of axes, including A and C axes.

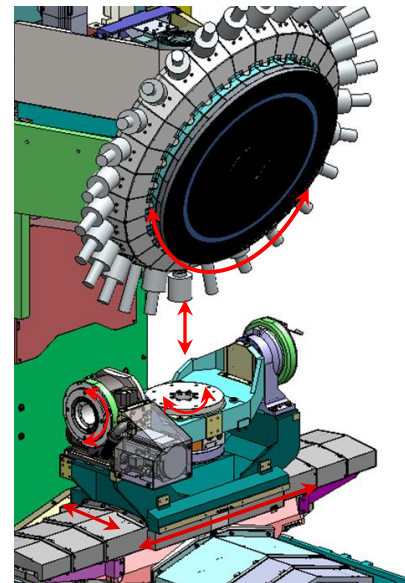

**Simultaneous
operation**

3. Performance and Features



**Extensive
Machine Performance**

**Pursuit of
High Productivity**

**Advanced
New D00 Control**

**Untiring Improvement
of Reliability**

Global Standard User Interface



Received “iF DESIGN AWARD 2021”
one of the top 3 design awards in the world.

Increased screen size
12.1-inch → 15-inch



Our standardized touch panel is made for onsite work conditions

- User operation like a smartphone
- Safe to use onsite

Consolidated Access on New Home Screen

Home Screen

Cycle time

Remaining time can also be displayed

Workpiece counter

Workpiece counters enabled in program are displayed

Tool life

5-tool display, starting from tool with shortest tool life

Support application keys



Program

Shortcut keys

Previous Screen

Touch panel can be changed to previous screen that user is accustomed to



Advanced User Interface Equipped with new “Support Applications” to help the user with everyday tasks



More Visibility

Production performance

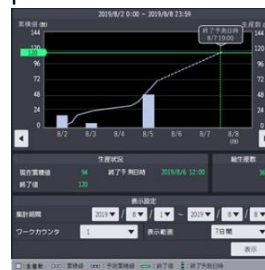

Operational performance



Power consumption



Task support

ATC tools

ID	名前	ステータス
01	TAP DR. 8 P.L.5	使用中
02	DRILL DR.8	使用中
03	DRILL DR.8	使用中
04	DRILL DR.8	使用中
05	DRILL DR.8	使用中
06	DRILL DR.8	使用中
07	DRILL DR.8	使用中
08	DRILL DR.8	使用中
09	DRILL DR.8	使用中
10	DRILL DR.8	使用中
11	DRILL DR.8	使用中
12	DRILL DR.8	使用中
13	DRILL DR.8	使用中
14	DRILL DR.8	使用中
15	DRILL DR.8	使用中
16	DRILL DR.8	使用中
17	DRILL DR.8	使用中
18	DRILL DR.8	使用中
19	DRILL DR.8	使用中
20	DRILL DR.8	使用中

Recovery support / Check

ID	名前	ステータス
01	リセット	使用中
02	リセット	使用中
03	リセット	使用中
04	リセット	使用中
05	リセット	使用中
06	リセット	使用中
07	リセット	使用中
08	リセット	使用中
09	リセット	使用中
10	リセット	使用中
11	リセット	使用中
12	リセット	使用中
13	リセット	使用中
14	リセット	使用中
15	リセット	使用中
16	リセット	使用中
17	リセット	使用中
18	リセット	使用中
19	リセット	使用中
20	リセット	使用中

Shorten cycle time settings

ツールタイプ	設定値	標準値
MC70	0.000	0.000
MC71	0.000	0.000
MC72	0.000	0.000
MC73	0.000	0.000
MC74	0.000	0.000
MC75	0.000	0.000
MC76	0.000	0.000
MC77	0.000	0.000
MC78	0.000	0.000
MC79	0.000	0.000
MC80	0.000	0.000

Many New Convenient Functions Added

■ Tap override

Spindle and cutting **Override Enabled** during tapping operation

***Tap return recovery operation also enabled**

*Excluding end mill tapping (G177/178)

■ Cycle time log

Keeps the most recent **20 records** for cycle time

■ Tool log

After selecting a record from the cycle time log,

the **cutting time of each tool** in that program **can be displayed**

■ Additional functions

- Accessories
- Multi-skip
- Program restart from (automatically) saved position
- Measure time for specified part
- Load monitor and predict overload display
- Multiple block support in MDI operation
- External sub program call
- Added new ST/FBD languages to internal PLC



実行開始日時	プログラム P	番線	サイクルタイム	切刃時間	非切刃時間	静時間
2020/06/03 15:51:29	1011	1	0000:00:02.7	0000:00:02.7	0000:00:00.0	0000:00:00.0
2020/06/03 15:52:41	1011	1	0000:00:03.3	0000:00:03.3	0000:00:00.0	0000:00:00.0
2020/06/03 15:53:29	1010	1	0000:00:02.7	0000:00:02.7	0000:00:00.0	0000:00:00.0
2020/06/03 15:54:34	1011	1	0000:00:02.7	0000:00:02.7	0000:00:00.0	0000:00:00.0
2020/06/03 15:55:26	1011	1	0000:00:02.7	0000:00:02.7	0000:00:00.0	0000:00:00.0
2020/06/03 15:56:19	1010	1	0000:00:02.7	0000:00:02.7	0000:00:00.0	0000:00:00.0
2020/06/03 15:57:13	1011	1	0000:00:02.7	0000:00:02.7	0000:00:00.0	0000:00:00.0
2020/06/03 15:58:04	1012	1	0000:00:02.7	0000:00:02.7	0000:00:00.0	0000:00:00.0
2020/06/03 15:59:47	1012	1	0000:00:02.7	0000:00:02.7	0000:00:00.0	0000:00:00.0
2020/06/03 16:00:32	1010	1	0000:00:02.7	0000:00:02.7	0000:00:00.0	0000:00:00.0
2020/06/03 16:01:23	1010	1	0000:00:02.7	0000:00:02.7	0000:00:00.0	0000:00:00.0
2020/06/03 16:02:18	1010	1	0000:00:02.7	0000:00:02.7	0000:00:00.0	0000:00:00.0
2020/06/03 16:03:01	1010	1	0000:00:02.7	0000:00:02.7	0000:00:00.0	0000:00:00.0
2020/06/03 16:03:49	1010	1	0000:00:02.7	0000:00:02.7	0000:00:00.0	0000:00:00.0
2020/06/03 16:04:34	1010	1	0000:00:02.7	0000:00:02.7	0000:00:00.0	0000:00:00.0
2020/06/03 16:05:21	1010	1	0000:00:02.7	0000:00:02.7	0000:00:00.0	0000:00:00.0
2020/06/03 16:06:09	1010	1	0000:00:02.7	0000:00:02.7	0000:00:00.0	0000:00:00.0
2020/06/03 16:06:57	1010	1	0000:00:02.7	0000:00:02.7	0000:00:00.0	0000:00:00.0
2020/06/03 16:07:44	1010	1	0000:00:02.7	0000:00:02.7	0000:00:00.0	0000:00:00.0
2020/06/03 16:08:32	1010	1	0000:00:02.7	0000:00:02.7	0000:00:00.0	0000:00:00.0
2020/06/03 16:09:20	1010	1	0000:00:02.7	0000:00:02.7	0000:00:00.0	0000:00:00.0
2020/06/03 16:10:09	1010	1	0000:00:02.7	0000:00:02.7	0000:00:00.0	0000:00:00.0
2020/06/03 16:10:57	1010	1	0000:00:02.7	0000:00:02.7	0000:00:00.0	0000:00:00.0

Cycle time log



番号	工具番号	切刃時間
1	1	0000:00:02.7
2	2	0000:00:03.3
3	3	0000:00:03.3
4	4	0000:00:03.3
5	5	0000:00:03.3
6	6	0000:00:02.7

Tool log



Accessories



Load monitor

Equipped with functions effective for multi-face machining

■ Rotary fixture offset G54.2 (optional)

Set the workpiece zero point on the rotary table.
This enables programming based on the workpiece zero point even when the rotary table is rotated.

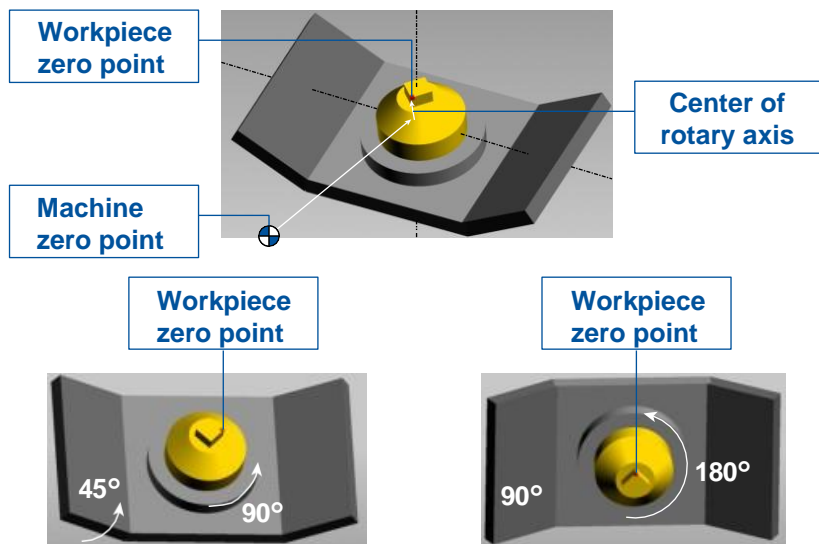

■ Feature coordinates setting G68.2 (optional)

Set the angle of the inclined surface relative to the workpiece.
This enables programming with workpiece coordinates for the specified surface.

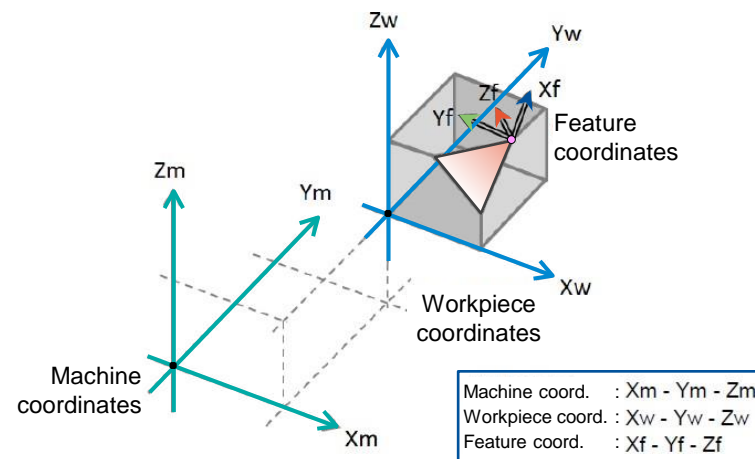

Hardware Specifications Upgrade

■ Faster block processing speed

Block processing is 4 times faster

■ More look ahead blocks in high accuracy mode B

Standard 40 → **160**

Option 200 → **1000**

■ Increased memory capacity, more workpiece zero point settings

◎ Memory capacity

Standard 100 MB → **500 MB**

Option 500 MB → **3 GB**

(Up to 4000 record files for both)

◎ Extended workpiece coordinate zero setting combinations

48 → **300**

■ Doubled tool data capacity (NC only)

99 → **198**

Tool life unit can be set to seconds

3D machining workpiece example

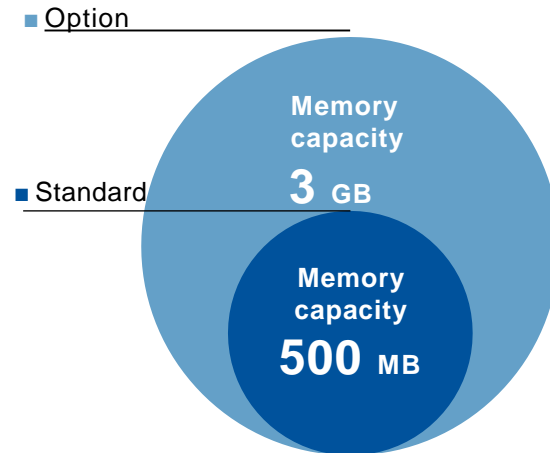

*Data comparison with CNC-C00

Added Compatible Standards

Added 2 types of industrial Ethernet:

Ethernet/IP and PROFINET to use on fieldbus networks, making the connection easier for users.

- CC-Link (M/S) *1
- Device Net (S)
- PROFIBUS-DP (S)
- **EtherNet/IP (S)**
- **PROFINET (S)**

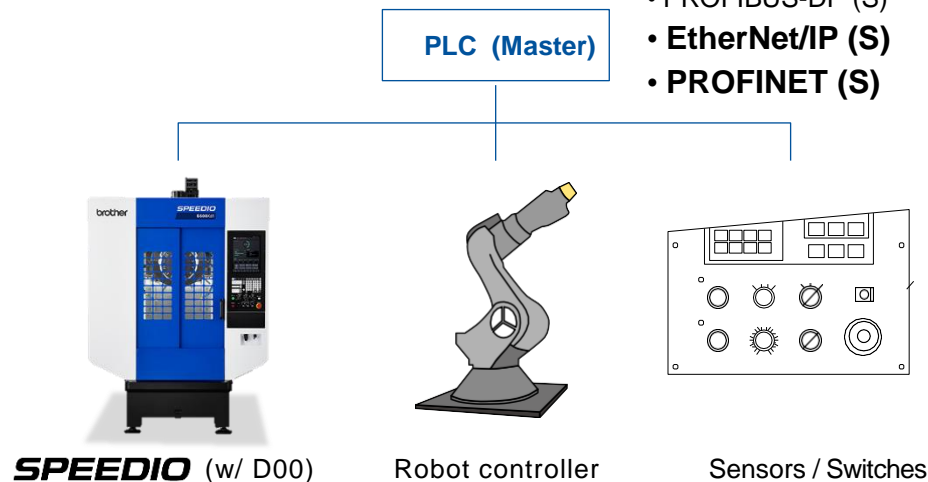

Support also for OPC UA

Users can now connect directly to other companies' monitor software that is compatible with OPC UA.



*1 PLC (Master) is not necessary for CC-Link (Master).

*2 Only 1 type can be selected from all the options for the fieldbus network.



Extensive
Machine Performance

Pursuit of
High Productivity

Advanced
New D00 Control

**Untiring Improvement
of Reliability**

Support for Faulty Workpiece Detection & Machine Collision Avoidance

■ ATC monitoring function

Detects problems due to attachment errors or in the event that a tool is forgotten.

- Mis-attachment to machine
- Tool holder missing



■ Machining load monitoring function

Detects increase in machining load.

Prevents outflow of defective workpiece caused by double machining.

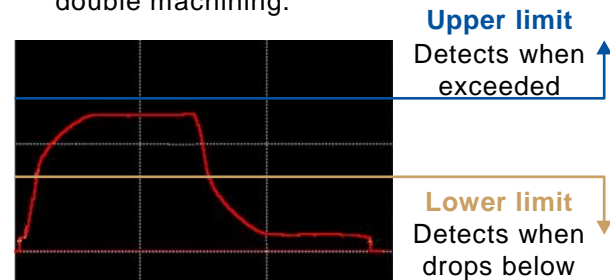

Improved chip evacuation

Entire surface of the base table has been inclined to improve chip evacuation performance.

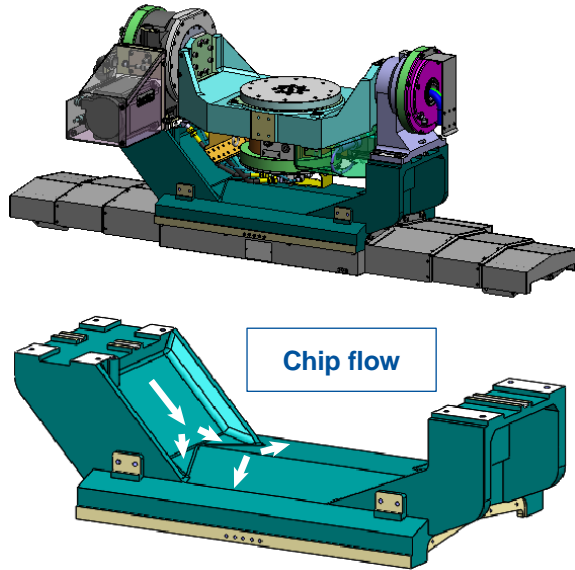

The size of the shower piping under the Y-axis telescopic cover has been enlarged to increase the volume of coolant discharge.

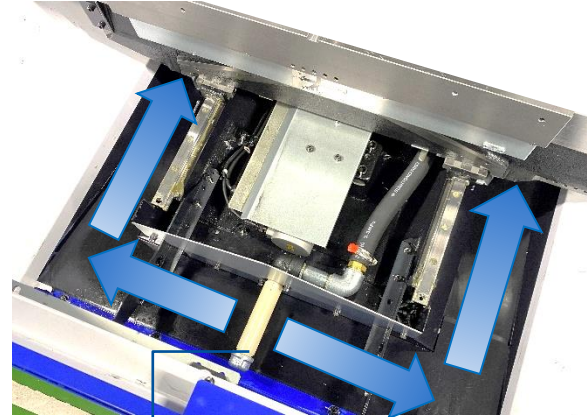

Increased volume of coolant discharge by enlarging shower piping size

Machine Specifications

Items			Details
Spindle	Taper		BT30 / BBT30 (optional)
	Spindle speed	min ⁻¹	10,000 / 16,000 (optional)
	CTS piping		Withstand pressure 3.0 MPa / 7.0 MPa
Travels	X / Y / Z	mm	500 / 400 / 300
	A (tilt axis) / C (rotary axis)	deg.	150 (-30 to +120) / 360
Rapid feed rate	X / Y / Z	m/min ⁻¹	50 / 50 / 56
	A / C	min ⁻¹	50 / 75 (60 *1)
Table	Work area size	mm	Φ260
	Max. loading capacity	kg	100
ATC	Tool storage capacity		14 / 21 (optional) / 28 (optional)
	Max. tool length	mm	250
	Max. tool weight	kg/tool	4.0 *2
NC unit			CNC-D00

*1: When using high inertia mode

*2: There are restrictions on spindle speed and total tool weight.



4. Machining demonstration

4. Machining demonstration

Process integration multi-face machining of automotive parts

Single-clamping multi-face machining using a built-in tilting rotary table

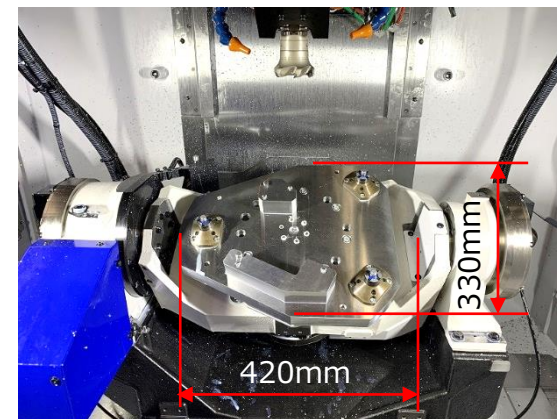
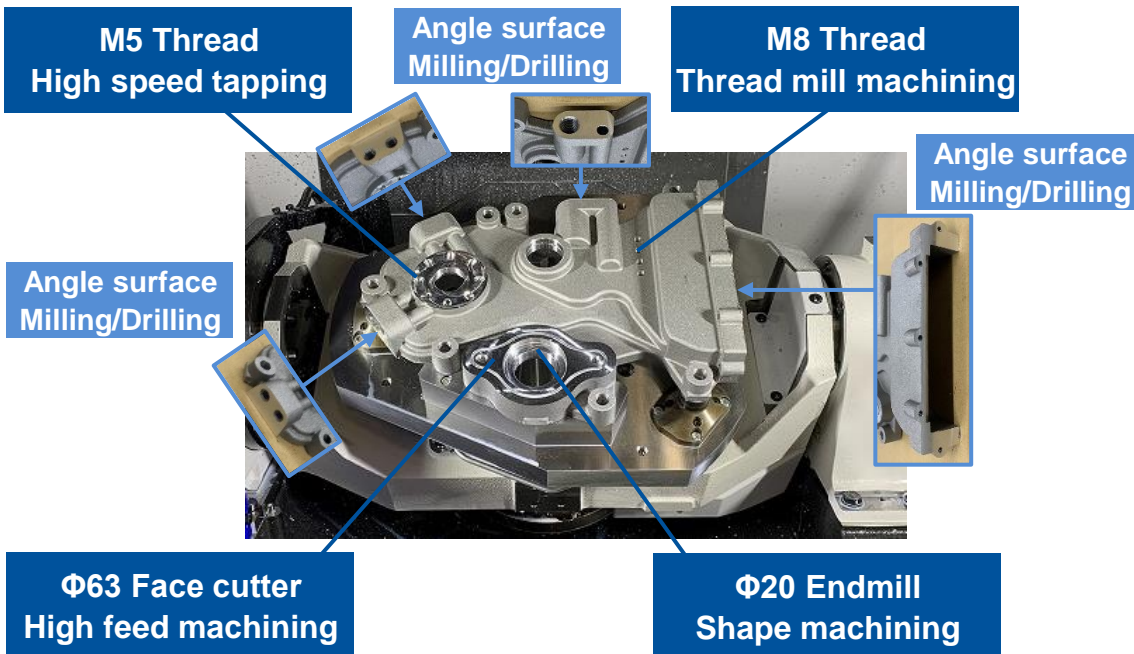

Hydraulic clamping system fixture

Workpiece	Timing chain cover
Workpiece material	Aluminum castings
Workpiece size	350x270x50mm
Fixture/workpiece weight	Approx. 60kg
Inertia around C-axis	0.99kg·m ²

brother
at your side